



Description

Excellent performance and IP69K rated robustness combined with a unique single-screw attachment

Electrical specifications

Device type

UHF RFID / EPCglobal Gen2v2

Operational frequency

Global 865-928MHz

IC type

Impinj M780

Memory configuration

EPC 496 bit; User 128 bit; TID 96 bit

EPC memory content

Unique number encoded as a default

Read range (2W ERP)*

On metal up 18m / 59 ft

On plastic up 7m / 23 ft

Applicable surface materials*

Optimized for metallic surfaces but may be used also on other materials.

* Read ranges are theoretical values that are calculated for non-reflective environment, in where antennas with optimum directivity are used with maximum allowed operating power according to ETSI EN 302 208 (2W ERP). Different surface materials may have an effect on performance

Mechanical specifications

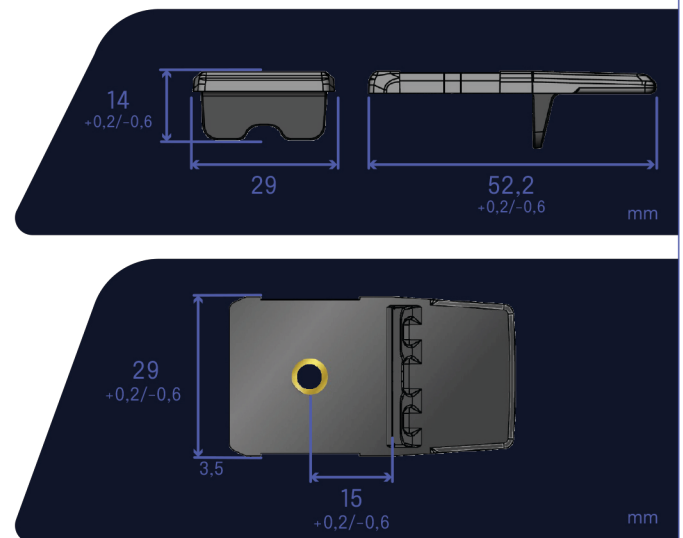

Tag materials

High quality thermoplastic elastomer

Amount in box

50 pcs

Dimensions

52,2 x 29 x 14 mm / 2.1 x 1.1 x 0.55 in (+0,2/-0,6mm)

Weight

5,5 g

Delivery format

Single

Radiation pattern

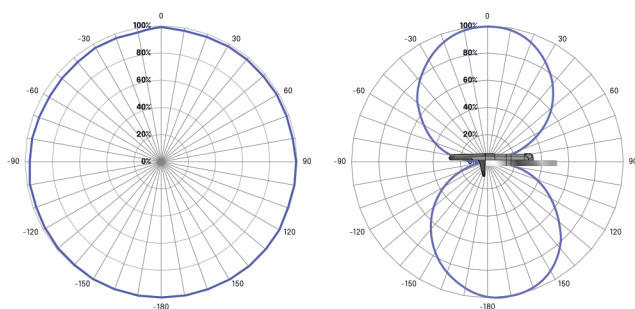

Radiation pattern is heavily affected by the shape of the tagged asset. Testing in real environment is recommended to find the best orientation and location for the tag.

Personalization options

Pre-encoding

Customer specific encoding of EPC or user memory. Locking permanently or with password.

Customized laser engraving

Customer specific layout including logo, text, numbers.



Environmental resistance

Operating temperature

-40°C to +85°C / -40°F to +185°F

Peak temperature

+140°C / +284°F for 10min

Water resistance

IP69K

Weather ability

Excellent, including UV-resistance and sea water

Values in the table are the best recommendations; resistance against environmental conditions depends on the combination of all influencing factors, exposure duration and chemical concentrations. Thus, product's final suitability for certain environmental conditions is recommended to be tested. Contact Confidex for more specific information.

Chemical resistance

No performance changes in:

- 168h NaOH (10%, pH 13)
- 168h Sulfuric Acid (10%, pH 2)

- 168h Motor oil
- 168h Salt water (salinity 10%)
- 2h Acetone

Storage condition

1 year in +20°C / 50% RH

Expected lifetime

Years in normal operating conditions



Installation instructions

Mechanical fixing is recommended in any application that includes a risk for mechanical stress. During fixing make sure there is no air gap left in between the surface and the tag. Note that the attachment hole should be located 15mm from the metal edge.

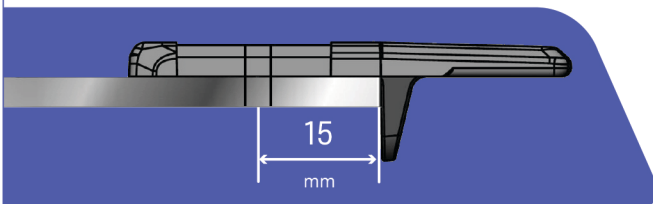

Attachment is made easier with the included metallic limiter that can withstand high torque. It is still recommended to use the screw or rivet with head size of at least 12mm (1/2 inch).

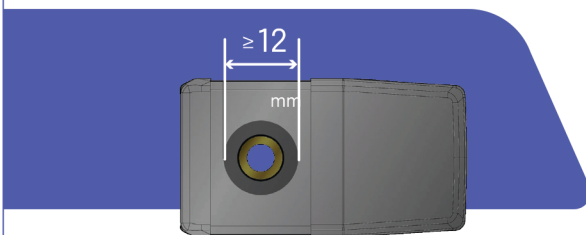

Performance of Ironside Flag may vary depending on installation location. Therefore it is recommended to test the optimal location for the tagged asset. You may also contact Confidex for recommendations



Order information

Product number: **3004421**

Product Name: **Beontag Ironside Flag M780**

DISCLAIMER

THE MATERIALS, PRODUCTS AND SERVICES ARE SOLD SUBJECT TO ITS STANDARD CONDITIONS OF SALE, WHICH ARE INCLUDED IN THE APPLICABLE DISTRIBUTOR OR OTHER SALES AGREEMENT. ALTHOUGH ANY INFORMATION, RECOMMENDATIONS, OR ADVICE CONTAINED HEREIN IS GIVEN IN GOOD FAITH, BEONTAG MAKES NO WARRANTY OR GUARANTEE, EXPRESS OR IMPLIED, (i) THAT THE RESULTS DESCRIBED HEREIN WILL BE OBTAINED UNDER END-USE CONDITIONS, OR (ii) AS TO THE EFFECTIVENESS OR SAFETY OF ANY DESIGN INCORPORATING ITS PRODUCTS, MATERIALS, SERVICES, RECOMMENDATIONS OR ADVICE. EXCEPT AS PROVIDED IN BEONTAG STANDARD CONDITIONS OF SALE, BEONTAG AND ITS REPRESENTATIVES SHALL IN NO EVENT BE RESPONSIBLE FOR ANY LOSS RESULTING FROM ANY USE OF ITS MATERIALS, PRODUCTS OR SERVICES DESCRIBED HEREIN.

Each user bears full responsibility for making its own determination as to the suitability of Beontag products, materials, services, recommendations, or advice for its own particular use. Each user must identify and perform all tests and analyses necessary to assure that its finished systems incorporating Beontag products, materials, or services will be safe and suitable for use under end-use conditions. Nothing in this or any other document, nor any oral recommendation or advice, shall be deemed to alter, vary, supersede, or waive any provision of this Disclaimer, unless any such modification is specifically agreed to in a writing signed by Beontag.

About Beontag

From the science of graphic and label materials, RFID and wireless IoT enablers, we create solutions across the value chain to deliver digital transformation for businesses around the world.

Sustainability is at the core of what we do and we strongly believe that by substituting non-renewable materials and innovating through more sustainable and renewable products, we act as an ESG enabler for our customers' value chain.

Beontag is one of the world's leading providers of RFID and wireless IoT solutions, being present in more than 40 countries with 7 R&D centers and 2,000 employees, in constant development of technological and sustainable solutions designed to connect items, and gain efficiency and end-to-end traceability

The performance of the product should always be tested in the actual application conditions. Our recommendations are based on our most current knowledge and experience and the pictures and illustrations presented in this document are for illustration purposes only. As our products are used in conditions beyond our control, we cannot assume any liability for damage caused through their use. Beontag reserves the right to change its products and services at any time without notice.



©Beontag



atlasRFIDstore

(205) 383-2244

sales@atlasRFIDstore.com

www.atlasRFIDstore.com