



Description

Printable and versatile UHF RFID label designed for hard-to-tag assets such as tubes and wires.

Electrical specifications

Device type

UHF RFID / EPCglobal Gen2v2

Air interface protocol

EPCglobal Class1 Gen2 ISO 18000-6C

Operational frequency

Global 865 - 928 MHz

IC type

Impinj Monza 4ETM

Memory configuration

EPC 496 bits, user 128 bits, TID 96 bits

EPC memory content

Same EPC by default

Read range (2W ERP)*

On metal pipe up to 7 m / 23 ft
On plastic pipe up to 5 m / 16 ft

Applicable surface materials*

All materials

* Read ranges are theoretical values that are calculated for non-reflective environment, in where antennas with optimum directivity are used with maximum allowed operating power according to ETSI EN 302 208 (2W ERP). ETSI = 865 - 868 MHz, FCC = 902 - 928 MHz. Different surface materials may have an effect on performance.

Delivery format

500 pcs / reel

Pitch on reel

With 150mm: 152,4 mm / 6 in
With 250mm: 254 mm / 10 in

Reel core inner diameter

76 mm / 3"

Tag dimensions

There are two items available with different strap length for various asset diameters.

150mm: 150 x 33 x 0.2 mm / 5.91 x 1.30 x 0.01"
250mm: 250 x 33 x 0.2 mm / 9.84 x 1.30 x 0.01"

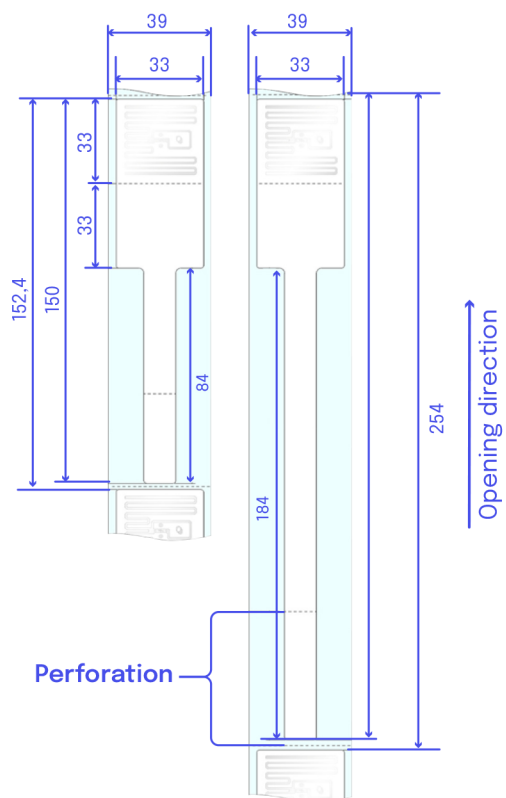

Mechanical specifications

Tag materials

Printable white PET, resin ribbon recommended.

Background adhesive

Permanent adhesive for general purpose use

Weight

< 1 g



Environmental resistance

Operating temperature

-40°C to +85°C / -40°F to +185°F

Water resistance

IP68, tested for 5 hours in 1m deep water

Chemical resistance

No physical or performance changes in:

- 168h Salt water (salinity 10%) exposure
- 168h Motor oil exposure
- 24h Sulfuric acid (10%, pH 2) exposure
- 24h NaOH (10%, pH 13) exposure
- 30min acetone exposure

Storage condition

1 year in +20°C / 50% RH (shelf life for adhesive)

Expected lifetime

Years in normal operating conditions

Values in the table are the best recommendations; resistance against environmental conditions depends on the combination of all influencing factors, exposure duration and chemical concentrations. Thus, product's final suitability for certain environmental conditions is recommended to be tested. Contact Beontag for more specific information.



Radiation pattern

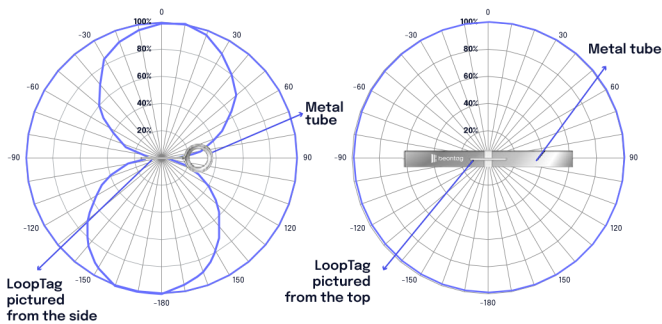

Personalization options

Pre-encoding

Customer specific encoding of EPC or user memory. Locking permanently or with password.

Customized printing

Customer specific layout including logo, text, numbers, barcodes etc.



Installation instructions

When attaching **Beontag LoopTag** please follow below instructions. During the attachment avoid touching the background adhesive. If the location on the asset needs to be changed, please use a new tag instead of opening the used one.

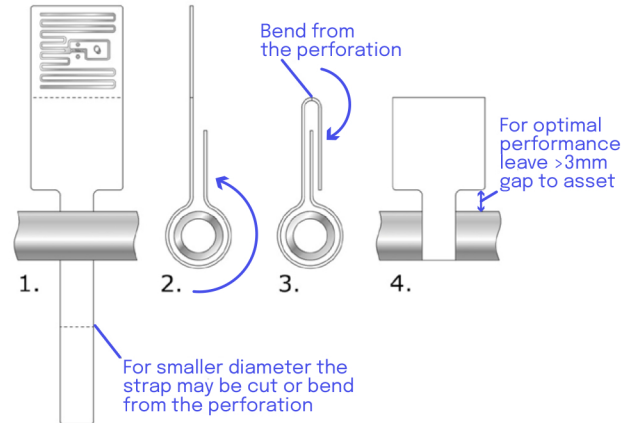

Ideal installation conditions are +20°C (+68°F) / 50% RH. For exceptional conditions, please contact Beontag. Bond strength can be improved with firm application pressure. Minimum bending diameter of the **Beontag LoopTag** is defined to be 50mm, excluding the strap part. Never touch on the location of the IC. Tag polarization should be taken into account in case liner polarized reader antennas are used.

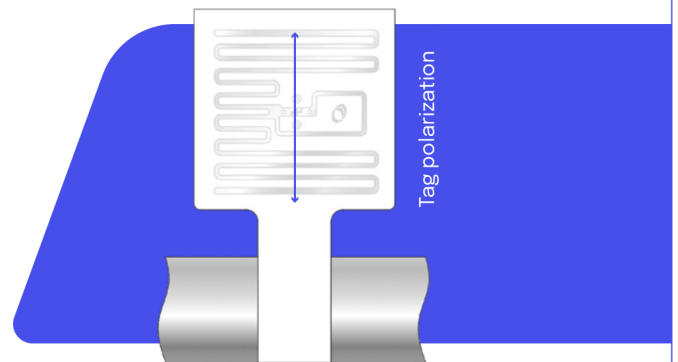

When printing the label align the printer gap trigger as shown below for smooth operation.

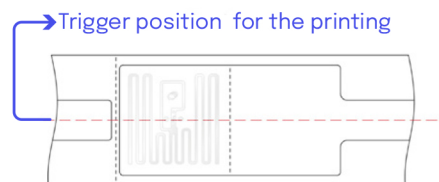



Order information

Product number: **3003452**
Product Name: **Beontag LoopTag M4E 150mm**

Product number: **3003519**
Product Name: **Beontag LoopTag M4E 250mm**

For other versions, additional information and technical support please contact Beontag.

DISCLAIMER

THE MATERIALS, PRODUCTS AND SERVICES ARE SOLD SUBJECT TO ITS STANDARD CONDITIONS OF SALE, WHICH ARE INCLUDED IN THE APPLICABLE DISTRIBUTOR OR OTHER SALES AGREEMENT. ALTHOUGH ANY INFORMATION, RECOMMENDATIONS, OR ADVICE CONTAINED HEREIN IS GIVEN IN GOOD FAITH, BEONTAG MAKES NO WARRANTY OR GUARANTEE, EXPRESS OR IMPLIED, (i) THAT THE RESULTS DESCRIBED HEREIN WILL BE OBTAINED UNDER END-USE CONDITIONS, OR (ii) AS TO THE EFFECTIVENESS OR SAFETY OF ANY DESIGN INCORPORATING ITS PRODUCTS, MATERIALS, SERVICES, RECOMMENDATIONS OR ADVICE. EXCEPT AS PROVIDED IN BEONTAG STANDARD CONDITIONS OF SALE, BEONTAG AND ITS REPRESENTATIVES SHALL IN NO EVENT BE RESPONSIBLE FOR ANY LOSS RESULTING FROM ANY USE OF ITS MATERIALS, PRODUCTS OR SERVICES DESCRIBED HEREIN.

Each user bears full responsibility for making its own determination as to the suitability of Beontag products, materials, services, recommendations, or advice for its own particular use. Each user must identify and perform all tests and analyses necessary to assure that its finished systems incorporating Beontag products, materials, or services will be safe and suitable for use under end-use conditions. Nothing in this or any other document, nor any oral recommendation or advice, shall be deemed to alter, vary, supersede, or waive any provision of this Disclaimer, unless any such modification is specifically agreed to in a writing signed by Beontag.

About Beontag

From the science of graphic and label materials, RFID and wireless IoT enablers, we create solutions across the value chain to deliver digital transformation for businesses around the world.

Sustainability is at the core of what we do and we strongly believe that by substituting non-renewable materials and innovating through more sustainable and renewable products, we act as an ESG enabler for our customers' value chain.

Beontag is one of the world's leading providers of RFID and wireless IoT solutions, being present in more than 40 countries with 7 R&D centers and 2,000 employees, in constant development of technological and sustainable solutions designed to connect items, and gain efficiency and end-to-end traceability

The performance of the product should always be tested in the actual application conditions. Our recommendations are based on our most current knowledge and experience and the pictures and illustrations presented in this document are for illustration purposes only. As our products are used in conditions beyond our control, we cannot assume any liability for damage caused through their use. Beontag reserves the right to change its products and services at any time without notice.



©Beontag

atlasRFIDstore

(205) 383-2244
sales@atlasRFIDstore.com
www.atlasRFIDstore.com