



Description

Small-sized NFC asset tag with versatile attachment options.

Electrical specifications

Device type

NFC Forum Type 2

Air interface protocol

ISO 14443A

Operational frequency

13,56 MHz

IC type

NXP NTAG213

Memory configuration

User memory 144 Bytes

Read range*

Mobile phone up to 30mm
Fixed reader up to 40mm

Applicable surface materials*

Works on any material

* Read ranges are measured in laboratory environment and there can be some variation in real application. Also used surface material might affect the read range.

Mechanical specifications

Tag materials

Engineering plastics and synthetic face layer

Background adhesive

High performance acrylic adhesive

Weight

2 g

Delivery format

Single

Amount in box

1000pcs

Dimensions

38 x 13 x 4,5 mm / 1.5 x 0.5 x 0.17 in

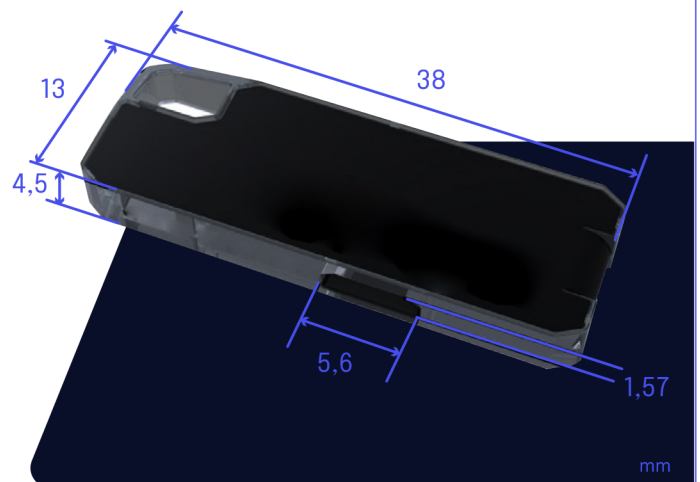

Personalization options

Pre-encoding

Customer-specific encoding.

Customized data label

Customer-specific layout including logo, text, numbers, barcodes etc.



Environmental resistance

Operating temperature

-20°C to +70°C / -4°F to +158°F

Ambient temperature

-20°C to +70°C / -4°F to +158°F

IP classification

IP67

Chemical resistance

No physical or performance changes in:

- 2 hour Salt water (salinity 10%) exposure
- 2 hour Motor oil exposure

Additionally, short time exposure resistant against sulfuric acid. Acetone and sodium hydroxide should be avoided.

Expected lifetime

Years in normal operating conditions

Values in the table are the best recommendations; resistance against environmental conditions depends on the combination of all influencing factors, exposure duration and chemical concentrations. Thus, product's final suitability for certain environmental conditions is recommended to be tested. Contact Beontag for more specific information.



Installation instructions

Beontag Steelwave Micro II NFC can be attached with several fixing methods:

- High performance acrylic adhesive (included)
- Hanging with tethering string
- Cable tie through the tag

When mounting the tag with its adhesive background, clean and dry the surface for obtaining the maximum bond strength.

Ideal application temperature is from +21°C to +38°C (+70°F to +100°F), bond strength can be improved with firm application pressure and moderate heating from +38°C to +54°C (+100°F to +130°F).

Installation at temperatures below 10°C (50°F) is not recommended.

**Order information**Product number: **3001301**Product name: **Beontag Steelwave Micro II NFC NTAG213**

For other versions, additional information and technical support please contact Beontag.

DISCLAIMER

THE MATERIALS, PRODUCTS AND SERVICES ARE SOLD SUBJECT TO ITS STANDARD CONDITIONS OF SALE, WHICH ARE INCLUDED IN THE APPLICABLE DISTRIBUTOR OR OTHER SALES AGREEMENT. ALTHOUGH ANY INFORMATION, RECOMMENDATIONS, OR ADVICE CONTAINED HEREIN IS GIVEN IN GOOD FAITH, BEONTAG MAKES NO WARRANTY OR GUARANTEE, EXPRESS OR IMPLIED, (i) THAT THE RESULTS DESCRIBED HEREIN WILL BE OBTAINED UNDER END-USE CONDITIONS, OR (ii) AS TO THE EFFECTIVENESS OR SAFETY OF ANY DESIGN INCORPORATING ITS PRODUCTS, MATERIALS, SERVICES, RECOMMENDATIONS OR ADVICE. EXCEPT AS PROVIDED IN BEONTAG STANDARD CONDITIONS OF SALE, BEONTAG AND ITS REPRESENTATIVES SHALL IN NO EVENT BE RESPONSIBLE FOR ANY LOSS RESULTING FROM ANY USE OF ITS MATERIALS, PRODUCTS OR SERVICES DESCRIBED HEREIN.

Each user bears full responsibility for making its own determination as to the suitability of Beontag products, materials, services, recommendations, or advice for its own particular use. Each user must identify and perform all tests and analyses necessary to assure that its finished systems incorporating Beontag products, materials, or services will be safe and suitable for use under end-use conditions. Nothing in this or any other document, nor any oral recommendation or advice, shall be deemed to alter, vary, supersede, or waive any provision of this Disclaimer, unless any such modification is specifically agreed to in a writing signed by Beontag.

About Beontag

From the science of graphic and label materials, RFID and wireless IoT enablers, we create solutions across the value chain to deliver digital transformation for businesses around the world.

Sustainability is at the core of what we do and we strongly believe that by substituting non-renewable materials and innovating through more sustainable and renewable products, we act as an ESG enabler for our customers' value chain.

Beontag is one of the world's leading providers of RFID and wireless IoT solutions, being present in more than 40 countries with 7 R&D centers and 2,000 employees, in constant development of technological and sustainable solutions designed to connect items, and gain efficiency and end-to-end traceability

The performance of the product should always be tested in the actual application conditions. Our recommendations are based on our most current knowledge and experience and the pictures and illustrations presented in this document are for illustration purposes only. As our products are used in conditions beyond our control, we cannot assume any liability for damage caused through their use. Beontag reserves the right to change its products and services at any time without notice.



©Beontag



atlasRFIDstore

(205) 383-2244

sales@atlasRFIDstore.com

www.atlasRFIDstore.com