



PC45 Series Desktop Printer

PC45d, PC45t*

Quick Start Guide

PC45-EN-QS-01 Rev B

**Additional model names may exist for specific countries*

07/23

Out of the Box

Make sure the shipping box contains these items:

- Printer
- USB Cable
- 0.5" Ribbon Core (PC45t only)
- Ribbon Notchless Core Adapters (PC45t SKU dependent)
- Test Print Label
- Power Adapter
- Power Cord (see note below)
- Product Compliance Insert

Note: *Power cord inclusion is SKU dependent and may need to be ordered separately. Contact your local sales representative for assistance.*

If you have ordered accessories for your printer, verify that they are included in the order. Be sure to keep the original packaging in case you need to return the printer.

Printer Features

PC45d

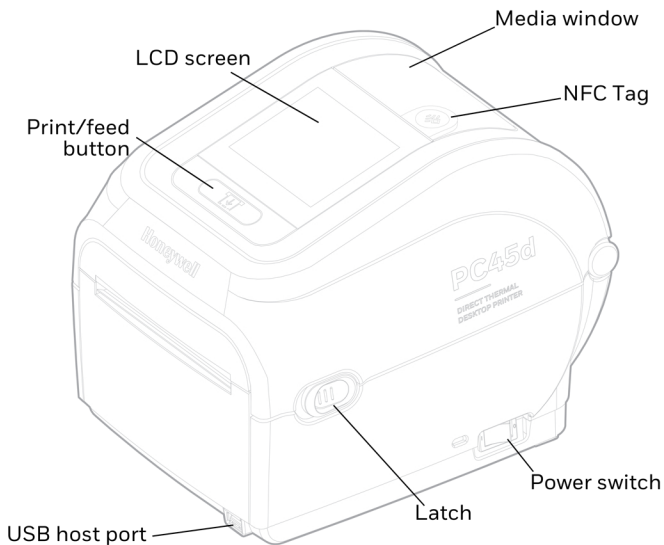

Note: NFC Tag is SKU dependent.

PC45d Internal View

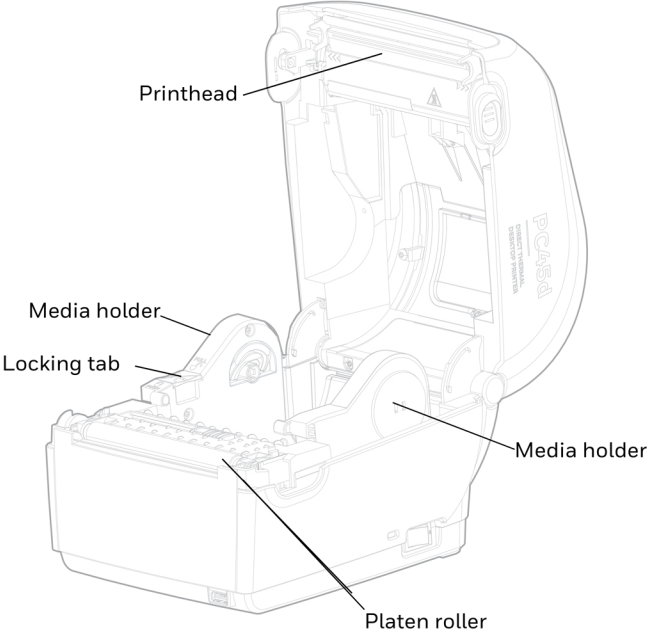

PC45t

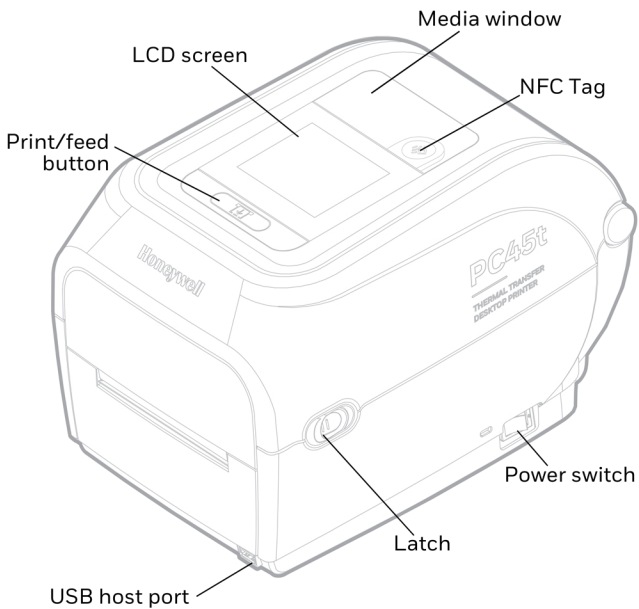

Note: *NFC Tag is SKU dependent.*

PC45t Internal View

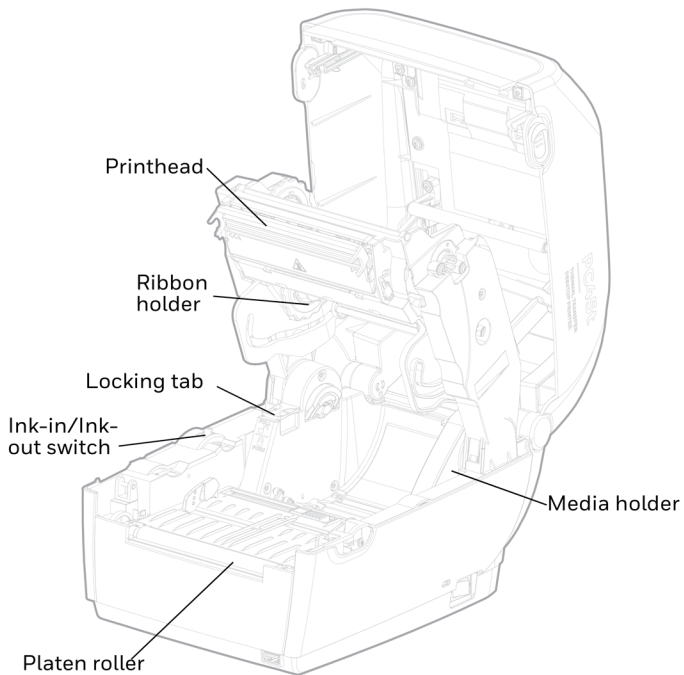

Set up Printer

Load Media

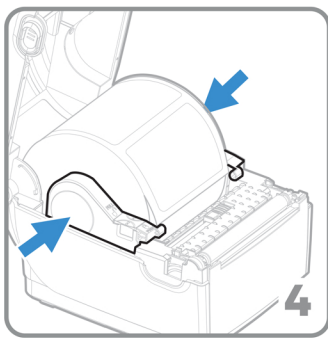
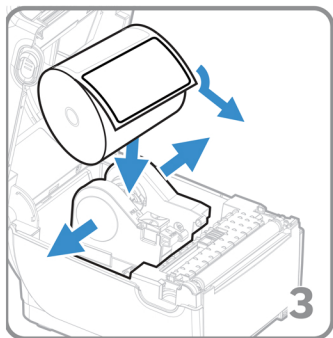
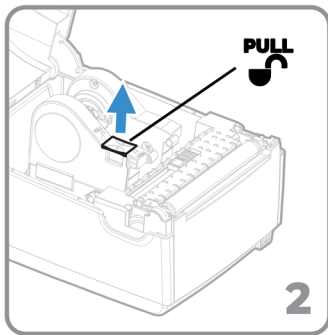
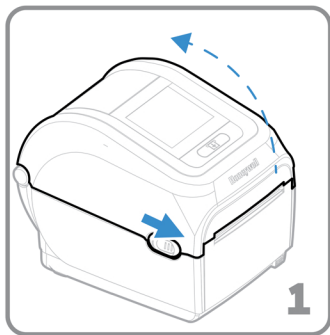

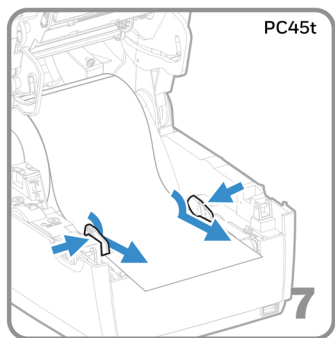
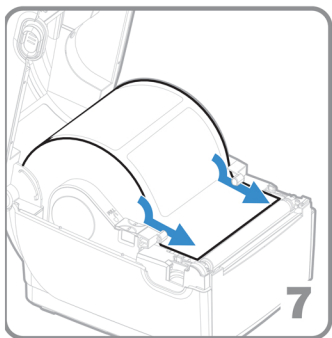
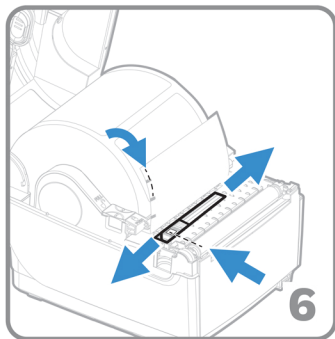
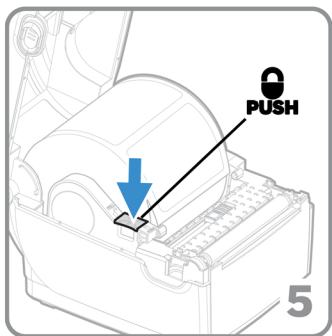

Load Ribbon for PC45t Printer

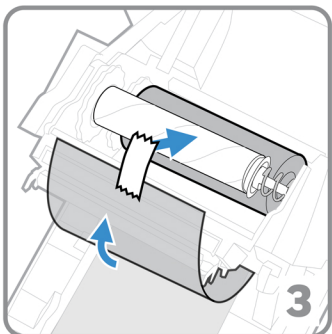
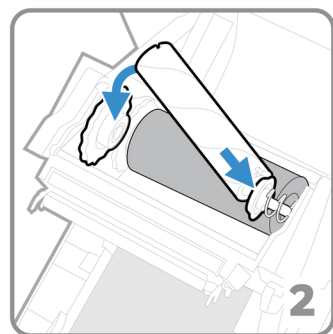
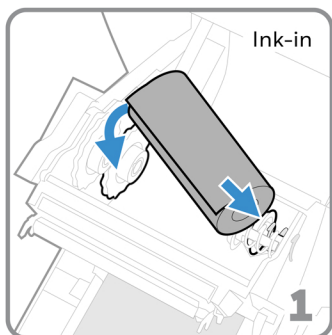
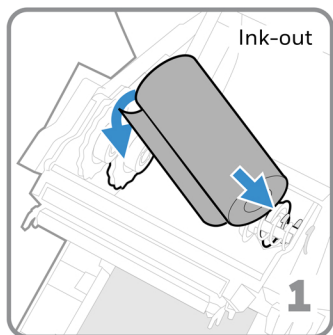

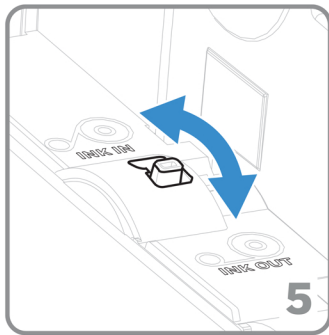
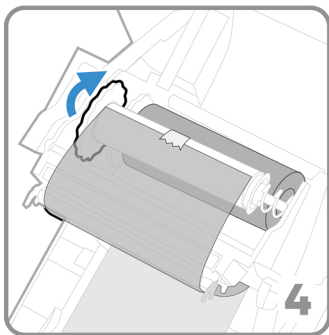

Close Printer Lid

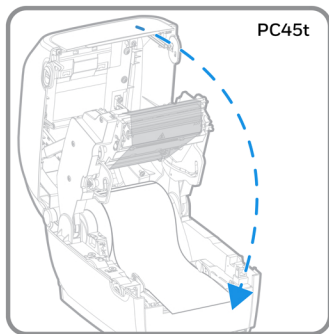
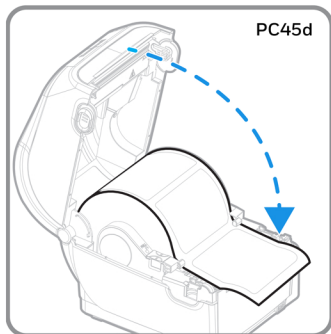

Power on Printer

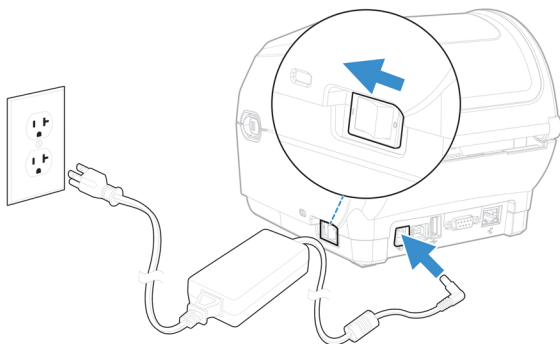

Note: Make sure the power switch of the printer is turned off before connecting the power cord.

Front Panel and Display

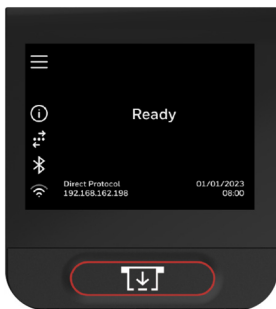







Print Button

Use the Print/Feed button to feed media, pause print jobs, calibrate, test feed, and print.

Printer State	Print Button Action
Startup	Press the Print/Feed button during startup to enter calibration mode or to restore defaults if the printhead is lifted.
Ready	Press the Print/Feed button to advance media. Press and hold the Print button for smart calibration.
Printing	Press the Print/Feed button to stop or pause printing. The printer stops after completing the current label.
Paused	Press the Print/Feed button to resume printing.
Error	Press the Print/Feed button to advance the media.

Main Menu Icons

Menu Icons	Description
	Press the icon to view the main menu for your printer.
	Press the icon to view communications information for your printer.
	Press the icon to view specific printer information.
	Press the icon to view Wi-Fi connectivity information.
	Press the icon to view Bluetooth/Bluetooth LE information for your printer.
	Press this icon to navigate back through the printer menus.

Note: To learn more about printer icons, see the user guide.

Print a Test Label

Once the printer is turned on, it runs a startup wizard to let you enter basic setup information.

1. Enter all the information on the wizard screen. Click **No** when prompted to run other wizards.
2. From the Ready screen, tap on the Main Menu .
3. From the Main Menu, tap **Tools > Test Labels**.
4. Select the test label you want to print and tap.

Your test label prints.

Support

To search our knowledge base for a solution or to log in to the Technical Support portal and report a problem, go to honeywell.com/PSStechnicalsupport.

Limited Warranty

For warranty information, go to sps.honeywell.com and then select **Support > Warranties**.

Patents

For patent information, see www.hsmpats.com.

Disclaimer

Honeywell International Inc. (“HII”) reserves the right to make changes in specifications and other information contained in this document without prior notice, and the reader should in all cases consult HII to determine whether any such changes have been made. HII makes no representation or warranties regarding the information provided in this publication.

HII shall not be liable for technical or editorial errors or omissions contained herein; nor for incidental or consequential damages resulting from the furnishing, performance, or use of this material. HII disclaims all responsibility for the selection and use of software and/or hardware to achieve intended results.

This document contains proprietary information that is protected by copyright. All rights are reserved. No part of this document may be photocopied, reproduced, or translated into another language without the prior written consent of HII.

Copyright © 2023 Honeywell Group of Companies. All rights reserved.



atlasRFIDstore

(205) 383-2244

sales@atlasRFIDstore.com

www.atlasRFIDstore.com