



keonn

Modular RFID
Components

AdvanReader-10™

USB RFID reader





Benefits:

- High-performance
- Small form factor
- Lightweight
- With optional embedded antenna
- Reduces time and cost of developing RFID systems

Applications:

- Access control
- Android-based systems*
- IoT applications
- Embedded applications

*Only supported with ADRD-M2-10 (two ports reader)

Product overview

AdvanReader-10 is a **small form factor, lightweight, high performance USB reader** with an **integrated antenna** (optional).

AdvanReader-10 is perfect for **IoT applications** and other **embedded** uses where a controller hardware already exists.

AdvanReader-10 requires an external controller to be operated.

SDK available for:

- Java
- C#
- C/C++

AdvanReader-10 comes in **six models**:



with integrated antenna



integrated antenna with enclosure



1 port with SMA connector, to operate with any antenna



1 port with SMA connector, with enclosure

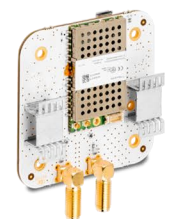

2 SMA connectors



2 SMA connectors, with enclosure

RF Common Specifications



Air Protocol Interface	EPC global UHF Class 1 Gen 2 / ISO 18000-6C
Supported regions	<p>FCC M1 versions FCC (NA2) (917.4 – 927.2) MHz FCC (NA3) (917.5 – 922.5) MHz M2 versions FCC (NA) (902 – 928) MHz FCC (NA2) (917.4 – 927.2) MHz FCC (NA3) (917.5 – 922.5) MHz FCC (NA4) (902 – 921) MHz</p> <p>ETSI (EU) (865.6 - 867.6) MHz ETSI Upper(EU) (916.3 - 918.7) MHz TRAI (India) (865 - 867) MHz KCC (Korea) (917 – 923.5) MHz MIC (Japan) (916.9 – 923.4) MHz ACMA (AU) (920 – 926) MHz NZ (New Zealand) (922 - 927) MHz SRRC-MII (P.R.China) (920.125 – 924.875) MHz MY (Malaysia) (919.0 – 923.0) MHz ID (Indonesia) (923.0 – 925.0) MHz PH (Philippines) (918.0 – 920.0) MHz TW (Taiwan) (922.0 – 928.0) MHz MO (Macao) (920.0 – 925.0) MHz RU (Russia) (866.0 – 868.0) MHz SG (Singapore) (920.0 – 925.0) MHz VN (Vietnam) (866.0 – 869.0) MHz TH (Thailand) (920.0 – 925.0) MHz AR (Argentina) (915.0 – 928.0) MHz HK (Hong Kong) (865.0 – 868.0) MHz BD (Bangladesh) (925.0 – 927.0) MHz</p> <p>Open Region M1 versions (859 – 873) MHz and (915 – 930) MHz M2 versions (840 – 869) MHz and (902 – 928) MHz</p>
Data communications	<p>USB power connector (micro-B) Communications uses RS232 over USB (FTDI chip)</p>
Power supply	<p>USB power connector (micro-B) The USB data connector is also used as the power supply source.</p> <p>Avoid USB cables with high losses: •Very long cables •Cables with high AWG values</p> <p><i>Make sure the USB host port offers enough current to operate ADRD-10 at the desired power level. The USB 2.0 specification defines 500 mA as the current offered by USB host ports, this is not enough to operate the reader at its maximum 27 / 30 dBm power level. Most modern HW offers enough power to operate the reader at maximum power.</i></p>
On-board sensors and actuators	RF amplifier temperature sensor (available through the reader API)
Temperature	-20 °C to +50 °C
Humidity	20 % to 85 % without condensation

Specifications of 1 port with embedded antenna



Max tag read throughput	Up to 150 tags/second
RF Power	Programmable from 0 dBm to 27 dBm in 0.5 dBm steps
Power consumption	Idle consumption < 1 W Max RF consumption (@27 dBm) < 4.5 W
Dimensions	Without enclosure: 67 mm x 67 mm x 12 mm (2.68 inches x 2.68 inches x 0.47 inches) With enclosure: 72mm x 72mm x 18mm (2.83 inches x 2.83 inches x 0.71 inches)
Weight	Without enclosure: EU version: 41.4 g (1.5 oz) US version: 54.7 g (1.9 oz) With enclosure: EU version: 101 g (3.6 oz) US version: 86.9 g (3.1 oz)

Specifications of 1 port with SMA connector



RF connector	One 50 ohm SMA connector SMA connector can be ordered as: <ul style="list-style-type: none"> • flange straight (only available without enclosure) • flange right angle • flange right angle 180 degrees rotation (only available without enclosure)
Max tag read throughput	Up to 150 tags/second
RF Power	Programmable from 0 dBm to 27 dBm in 0.5 dBm steps
Power consumption	Idle consumption < 1 W Max RF consumption (@27 dBm) < 4.5 W
Dimensions	Without enclosure: FL 68 mm x 68 mm x 21.5 mm (2.68 inches x 2.68 inches x 0.84 inches) FR 68 mm x 68 mm x 25 mm (2.68 inches x 2.68 inches x 0.98 inches) With enclosure: 72mm x 80mm x 23mm (2.834 inches x 3.17inches x 0.91inches)
Weight	Without enclosure: 32 g (1.3 oz) With enclosure: 98g (3.46oz)

Specifications of 2 ports with two SMA connector

RF connector	Two 50 ohm SMA right angle connectors
Max tag read throughput	Up to 50 tags/second
RF Power	Programmable from 0 dBm to 30 dBm in 0.5 dBm steps
Power consumption	Idle consumption < 1 W Max consumption (@30 dBm) < 9.5 W
Dimensions	Without enclosure: 78mm x 67mm x 14.28mm (3.07inches x 2.63 inches x 0.56 inches) With enclosure: 82 mm x 72 mm x 23 mm (3.23 inches x 2.83 inches x 0.91 inches)
Weight	Without enclosure: 40.3 g (1.41 oz) With enclosure: 95.6g (3.37oz)

Mechanical specifications
(with integrated antenna, EU version):

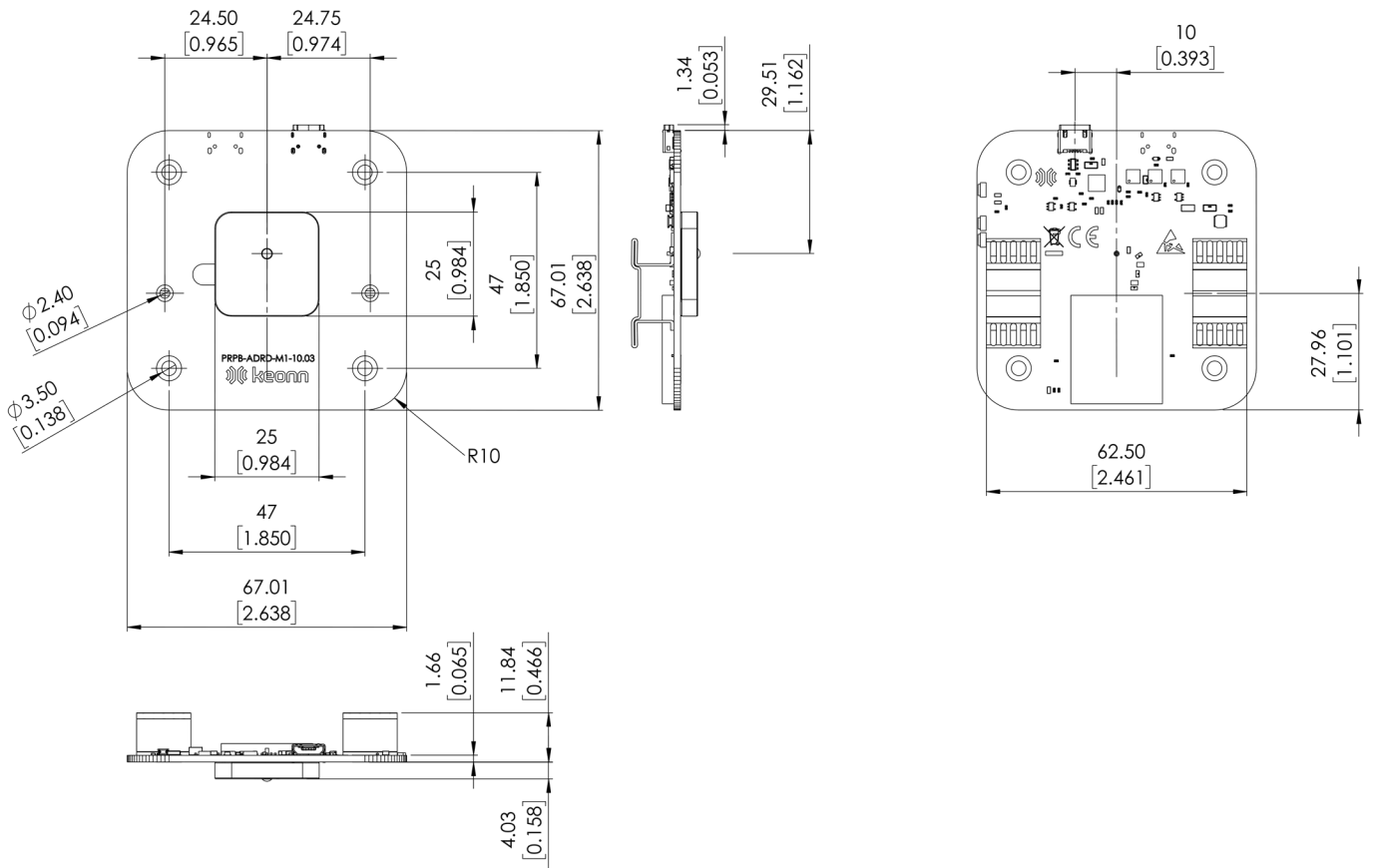
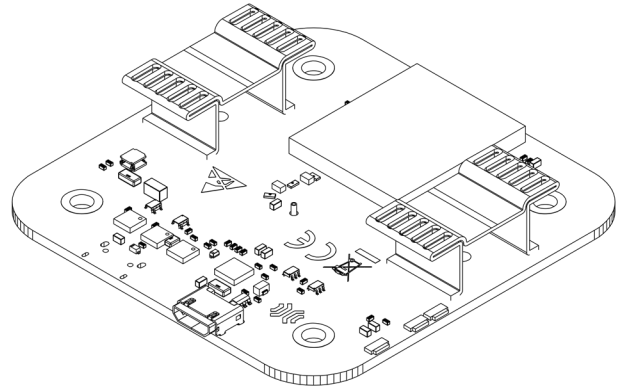
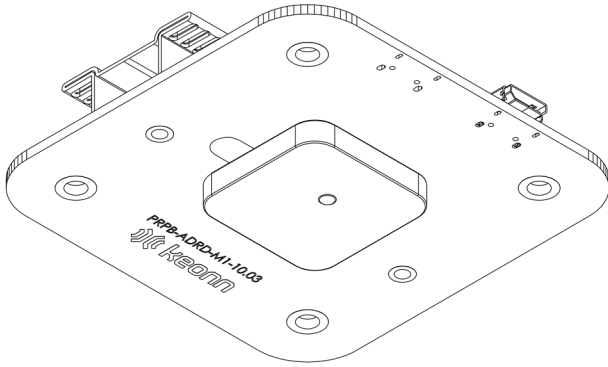

Units in millimeters and [inches]

Mechanical specifications
(with integrated antenna, US version):

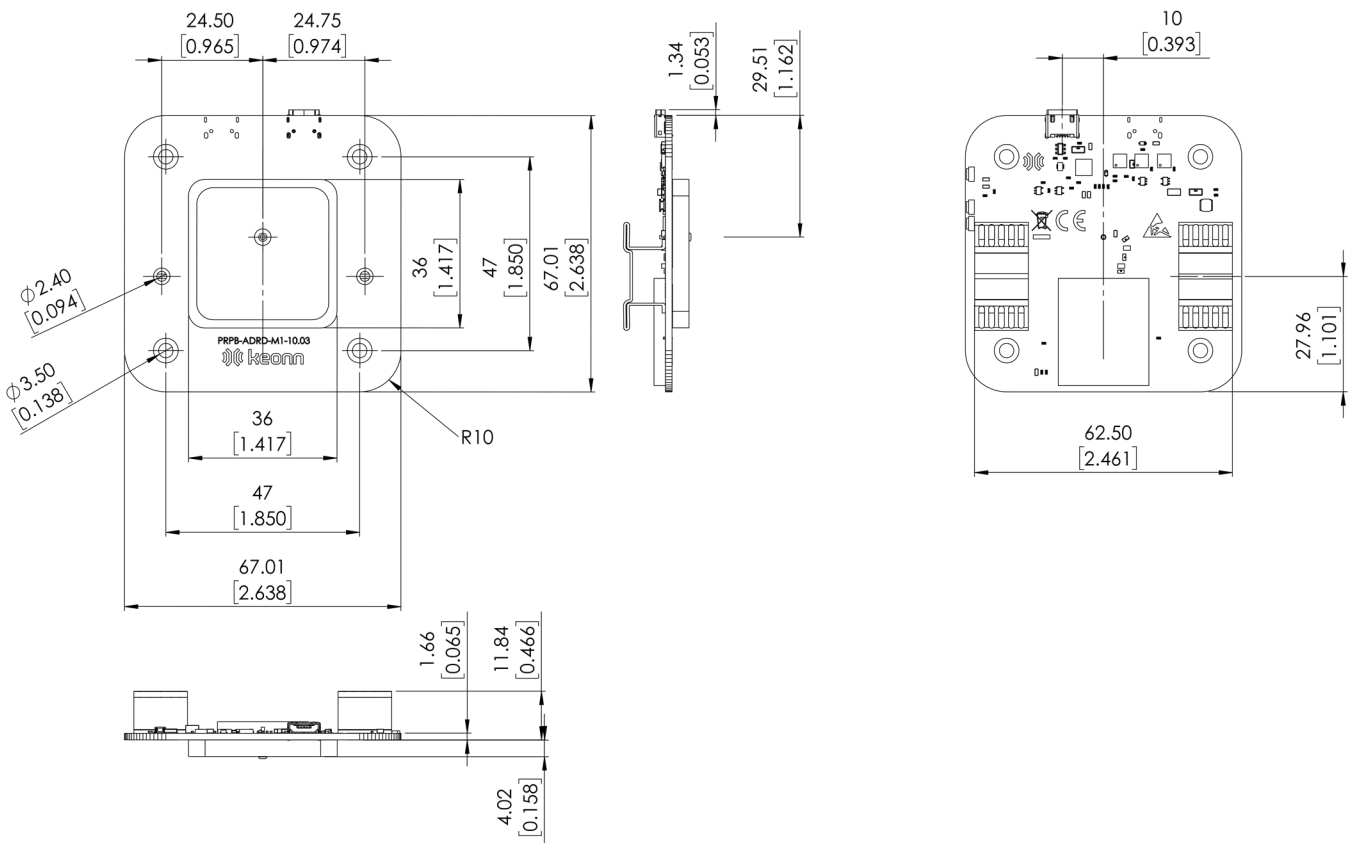
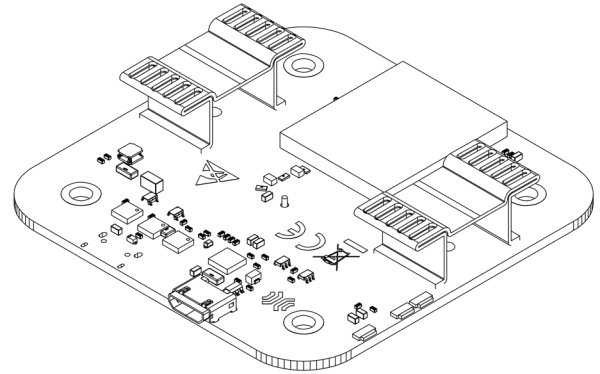
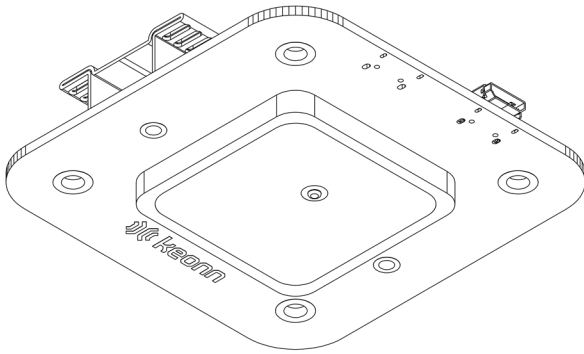

Units in millimeters and [inches]

Mechanical specifications
(1 port without enclosure, Flange straight SMA):

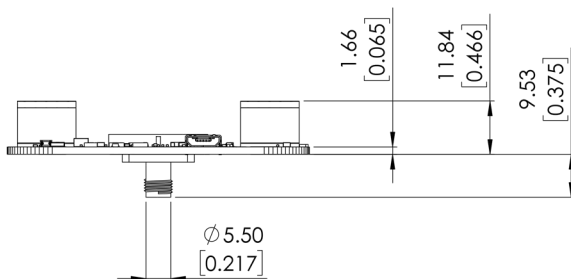
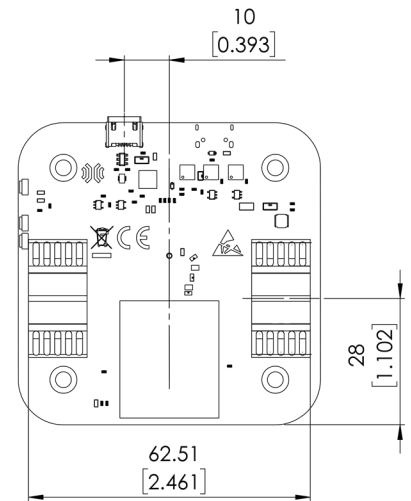
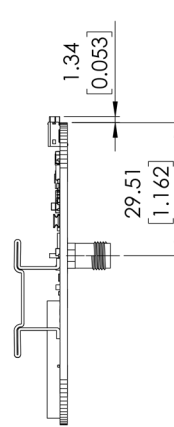
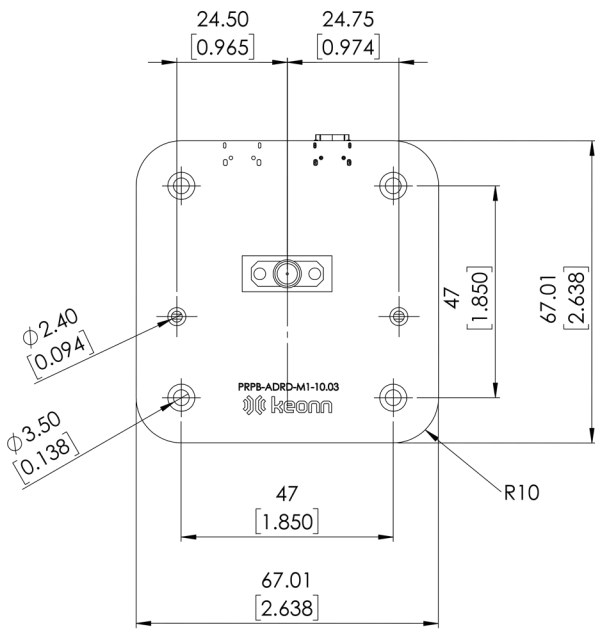
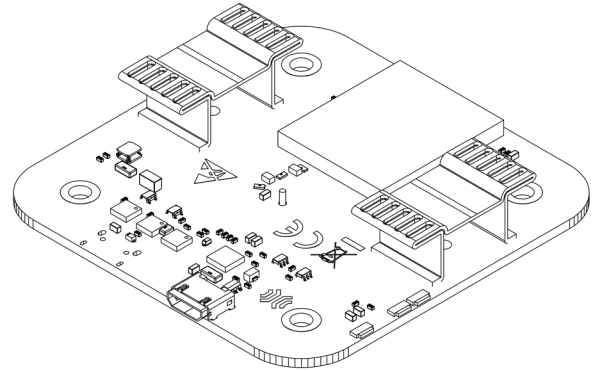
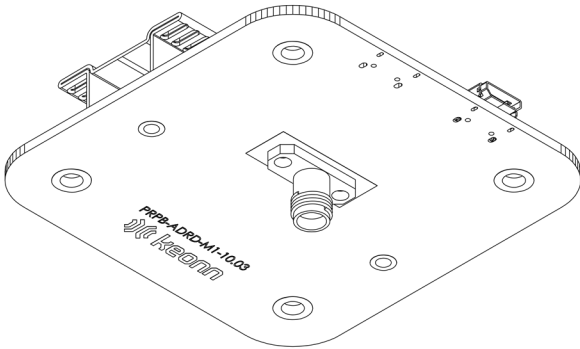

Units in millimeters and [inches]

Mechanical specifications

(1 port without enclosure, Flange right angle, SMA):

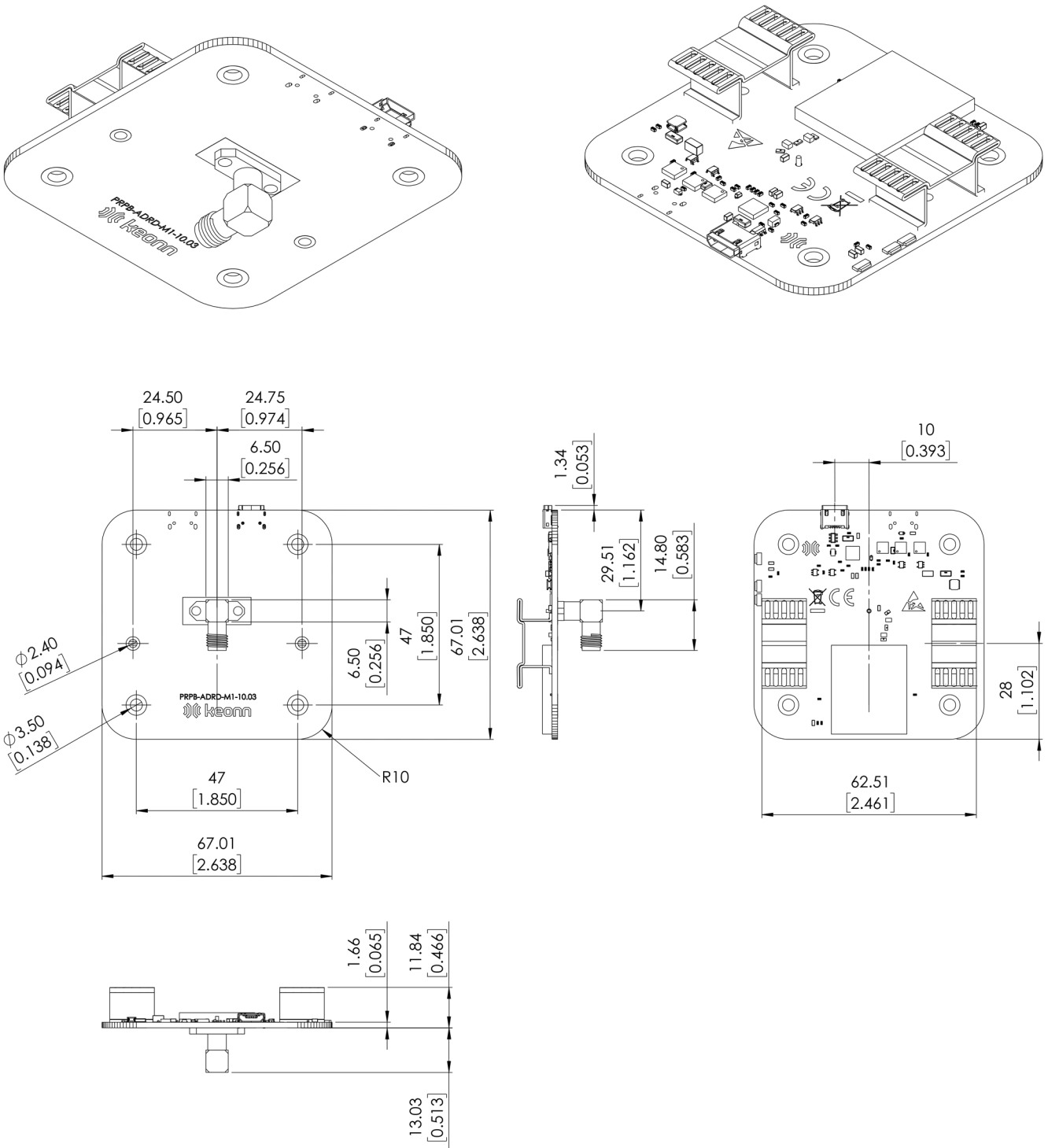

Units in millimeters and [inches]

Mechanical specifications
(integrated antenna, with enclosure):

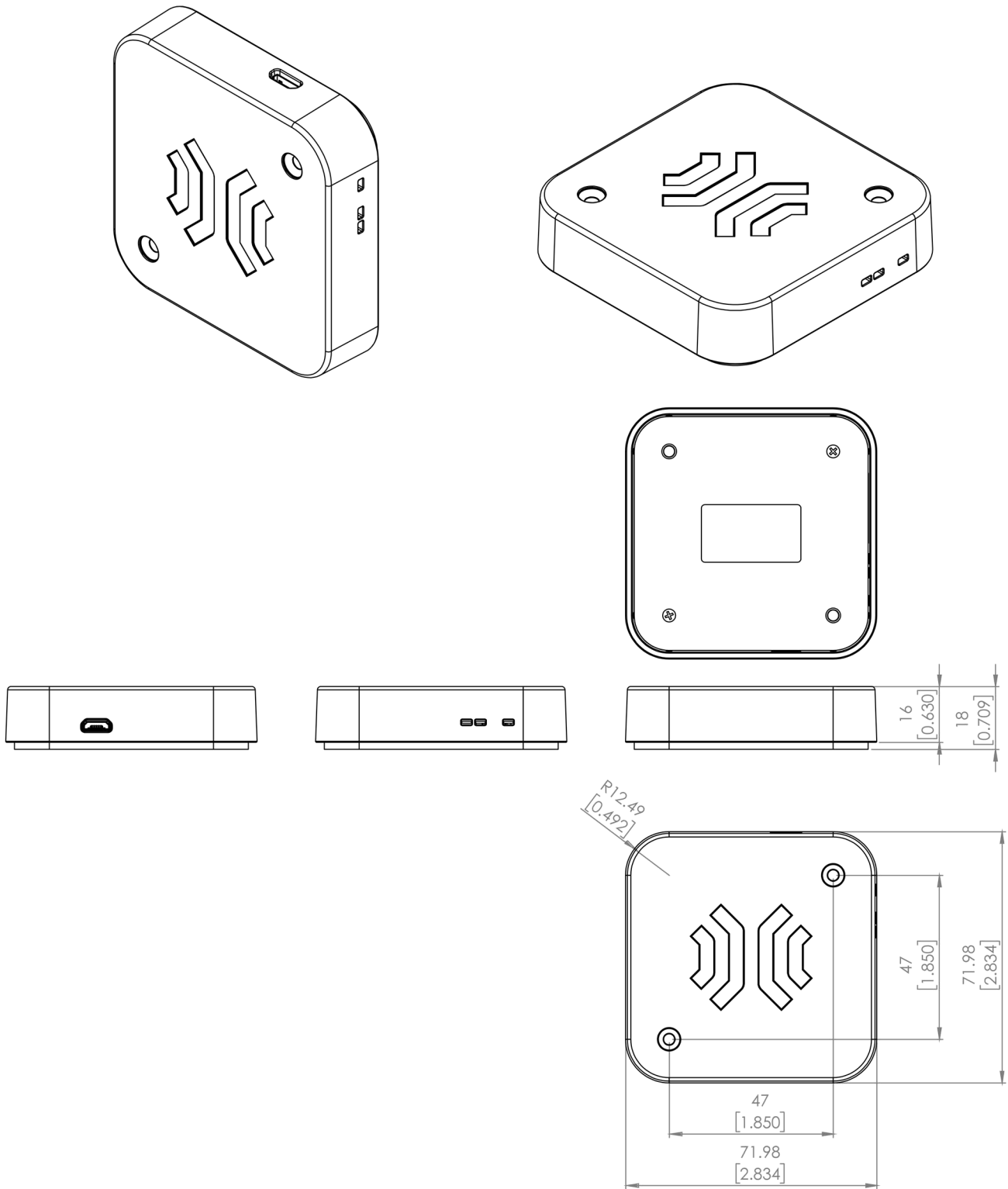

Units in millimeters and [inches]

Mechanical specifications
(1 port with enclosure, external antenna):

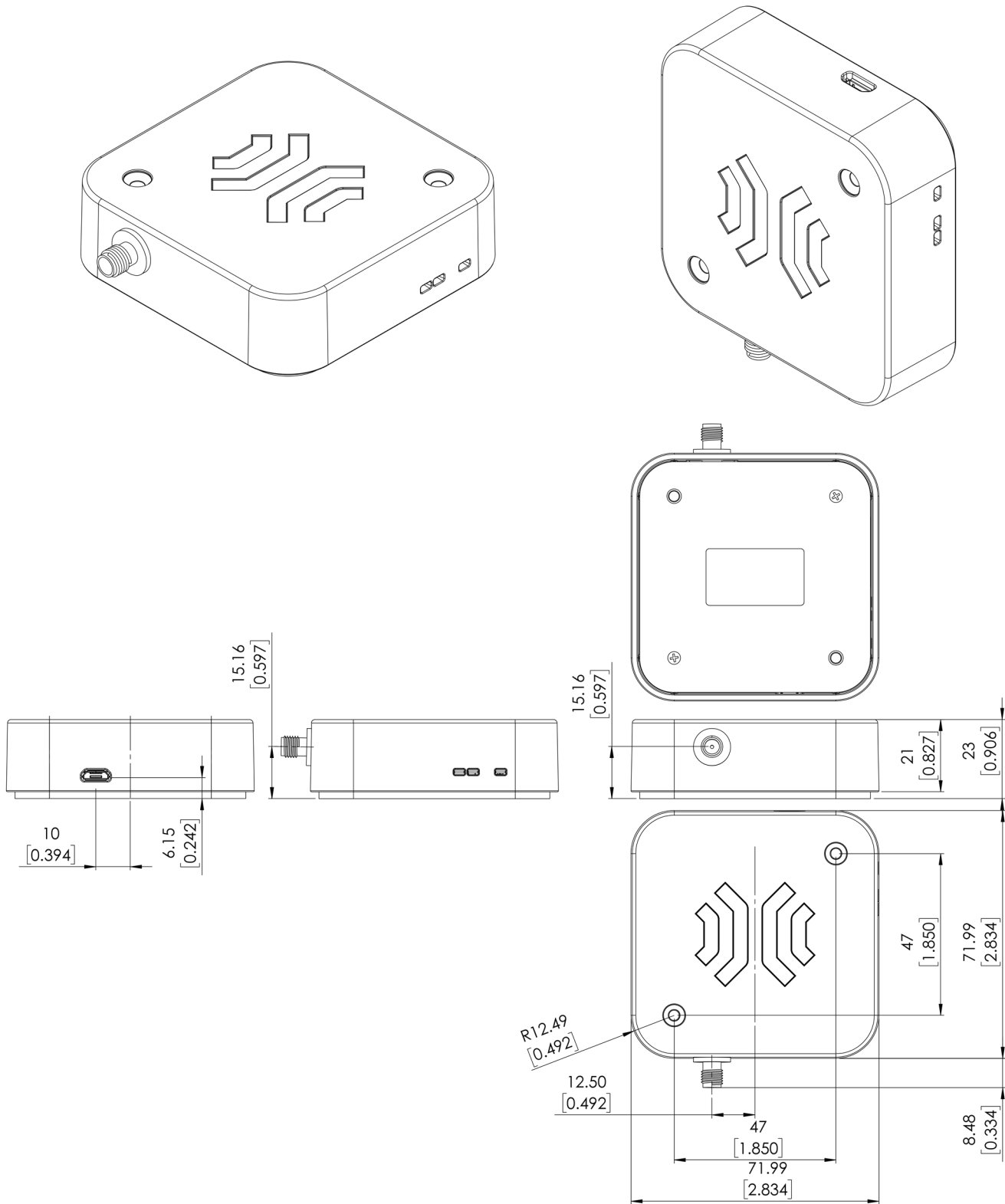

Units in millimeters and [inches]

Mechanical specifications
(2 ports, without enclosure):

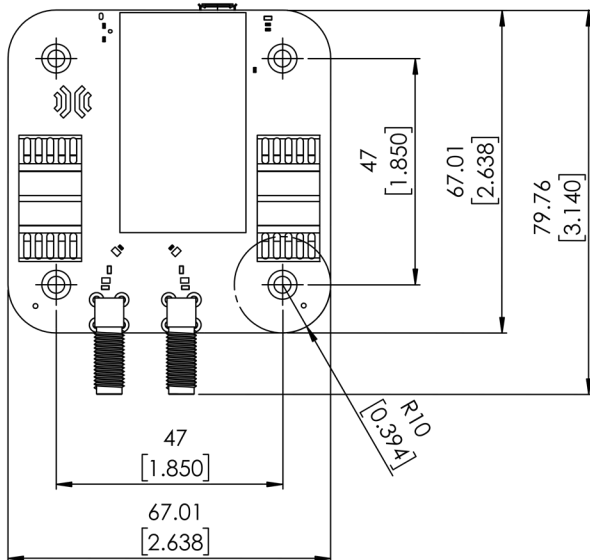
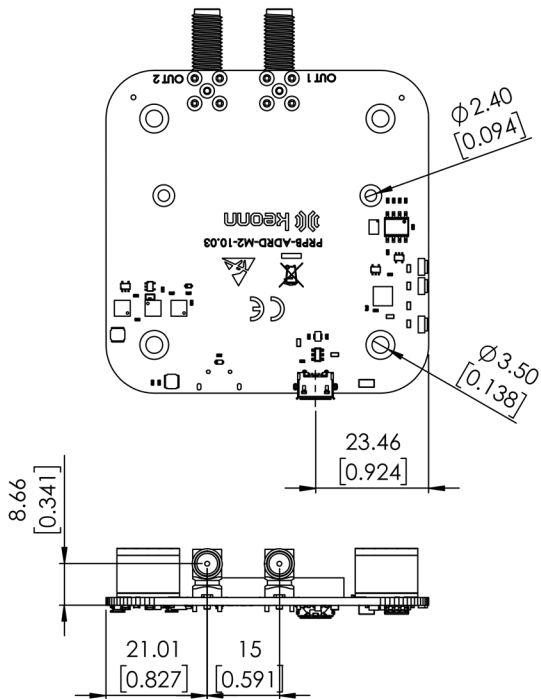
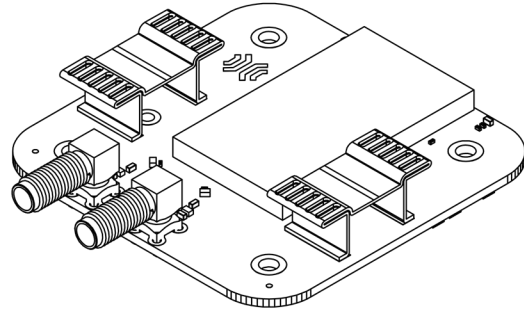
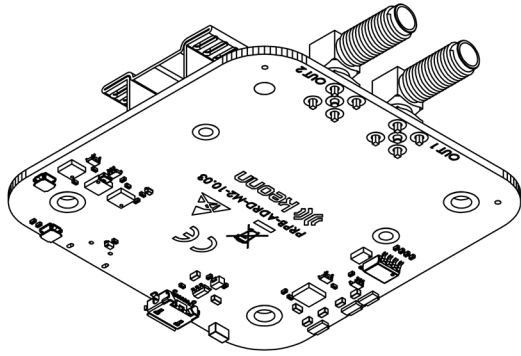

Units in millimeters and [inches]

Mechanical specifications
(2 ports, with enclosure):

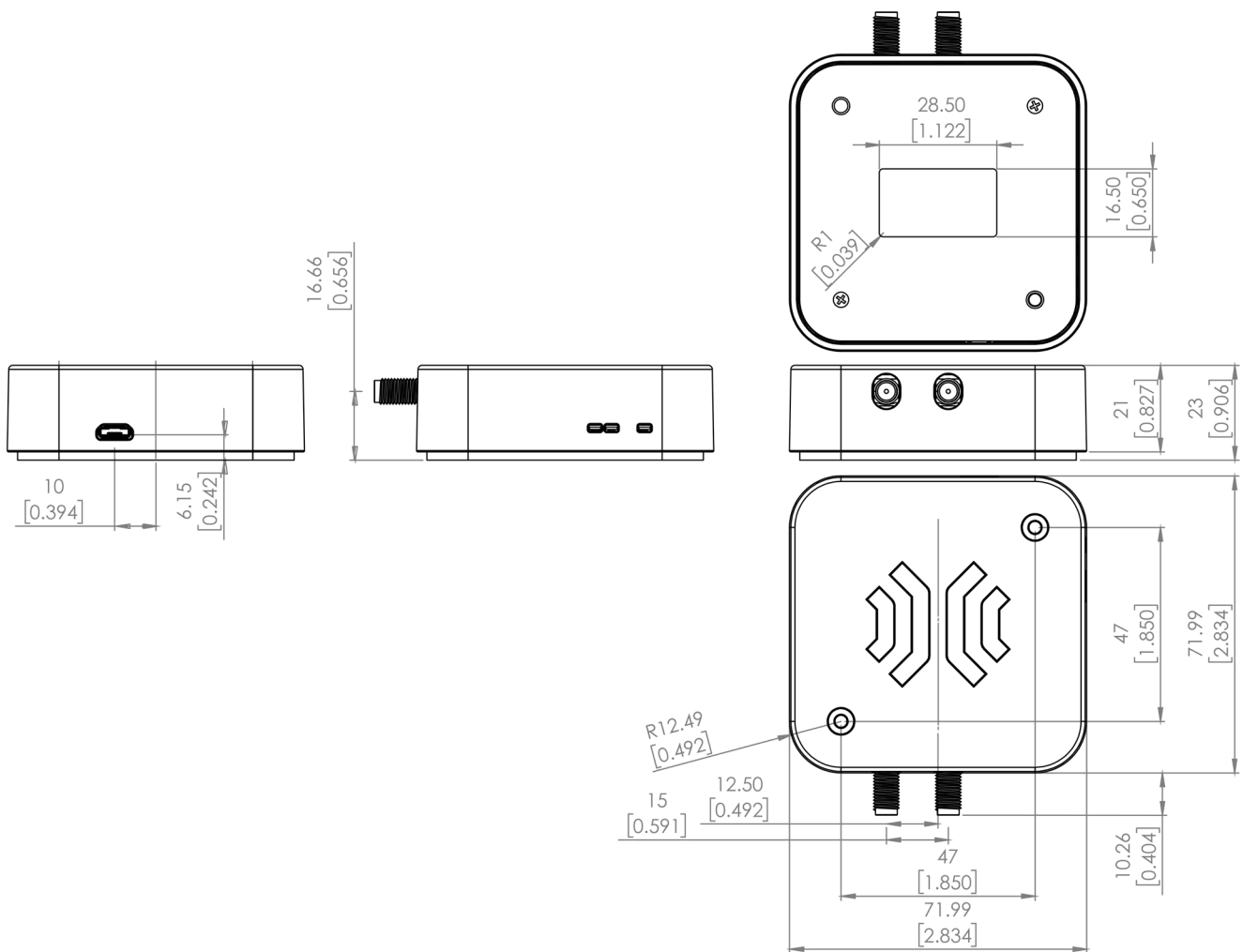
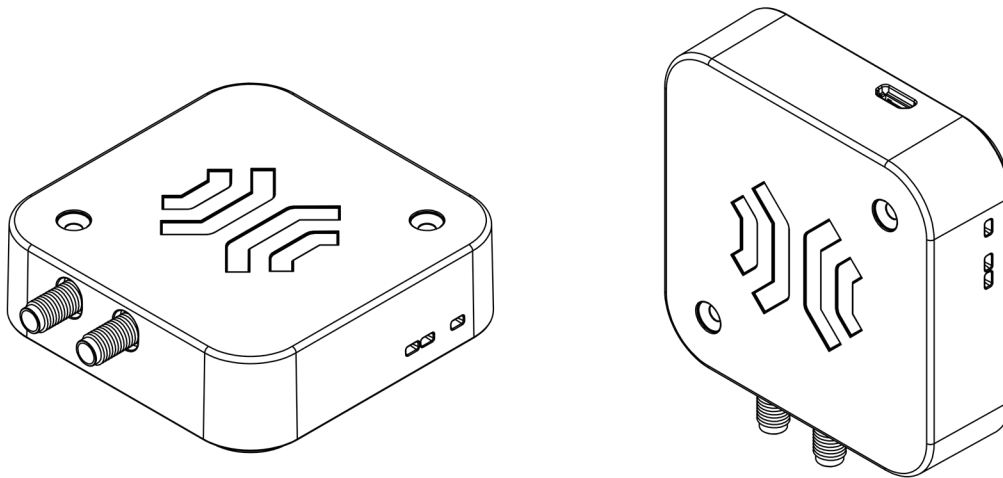

Units in millimeters and [inches]

Product codes for ordering

ADDR	-	MX	-	CT	-	FF	-	SC
MX = number of ports								
		M1						1 port
		M2						2 ports
CT = connector type								
								For 1 port:
				-				No connector, embedded antenna
				FLSMA				Flange straight, SMA version
				FRSMA				Flange right angle, SMA version
				FR180SMA				Flange right angle, 180 rotated SMA version
				eSMA				SMA connector, with enclosure
								For 2 port:
				SMA				Flange right angle SMA version
				eSMA				Flange right angle SMA version, with enclosure
FF = frequency band								
						EU		With embedded ETSI antenna (865,6 MHz - 867,6 MHz)
						US		With embedded FCC antenna (902,0 MHz - 928,0 Mhz)
						-		With connector, multiple bands
SC = series code								
							10	Series 10

Note: CT and FF options are exclusive, either one or the other exists in one product model

Examples:

ADDRD-m1-EU-10:

- AdvanReader
- 1 port
- With embedded antenna
- EU frequency band
- Model **10**

ADDRD-m1-FLSMA-10:

- AdvanReader
- 1 port
- With flange straight SMA connector
- Model **10**

ADDRD-m2-eSMA-10:

- AdvanReader
- 2 port
- With enclosure
- Model **10**



Copyright © Keonn Technologies S.L.
All rights reserved.

Information in this publication
supersedes all earlier versions.
Specifications subject to change
without notice.



atlasRFIDstore

(205) 383-2244

sales@atlasRFIDstore.com

www.atlasRFIDstore.com