

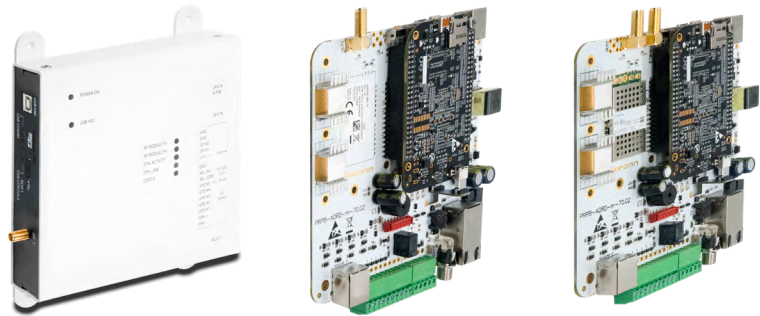

AdvanReader-70™

1 or 2 port RFID UHF reader





Benefits:

- High flexibility (1 or 2 ports)
- On board computer with fully open Linux OS
- Small form factor
- 2 digital/analog inputs
- 5 digital outputs and 1 relay output
- Acts as HID USB device
- Reduces time and cost of developing RFID systems
- You can make it your own reader by putting your company logo on the enclosure
- Direct connection to an external loudspeaker

Applications:

- Smart shelves
- Smart display fixtures
- Smart surfaces
- RFID portals
- RFID tunnels
- Point of Sales
- Loss prevention systems
- In general, any RFID application

Product overview

AdvanReader-70 is a flexible UHF reader with an on-board microcomputer and a fully open Linux operating system.

AdvanReader-70 comes with **two models**:

- 1 port, 27 dBm maximum output power
- 2 port, 30 dBm maximum output power

Thanks to its on-board microcomputer, AdvanReader-70 can work **stand-alone**, without needing to be connected to an external computer, thereby reducing equipment costs, installation costs, and maintenance costs.

Additional product features

AdvanReader-70 is also very flexible in terms of **inputs** and **outputs**:

- 5 x digital outputs and 1 relay output
- 2 digital/analog inputs
- Direct LED connections
- Loudspeaker: 8 ohm/2 W

AdvanReader-70 can become **your own reader**: your company logo can be the only logo on the enclosure.

AdvanReader-70 includes several **actuators** and **indicators** on-board:

- On-board buzzer
- On-board LED indicators for: power on (white), RF Tx (red), RF Rx (green), status (orange), etc.

AdvanReader-70 has small form factor (137 mm x 137 mm x 24 mm) and can be used in any RFID application.

AdvanReader-70 comes with a comprehensive set of built-in HW/SW communication options:

- USB HID emulation: allows generating keyboard events based on Reader events.
- HTTP: user-configurable HTTP request generation based on Reader events.
- MQTT: user-configurable MQTT packet generation based on Reader events.
- SQL: user-configurable SQL sentence generation based on Reader events.
- TCP: real-time TCP socket of Reader events.

AdvanReader-70™

1 or 2 port RFID UHF reader

Common RF specifications of all AdvanReader-70 models



Air Protocol Interface	EPC global UHF Class 1 Gen 2 / ISO 18000 - 6 C
Supported regions	<p>FCC (NA, SA) (902 to 928) MHz ETSI (EU) (865.6 to 867.6) MHz TRA (India) (865 to 867) MHz KCC (Korea) (917 to 923.5) MHz MIC (Japan) (916.9 to 923.4) MHz ACMA (AU) (920 to 926) MHz NZ (New Zealand) (922 to 927) MHz SRRC-MII (P.R.China) (920.125 to 924.875) MHz MY (Malaysia) (919.0 to 923.0) MHz ID (Indonesia) (923.0 to 925.0) MHz PH (Philippines) (918.0 to 920.0) MHz TW (Taiwan) (922.0 to 928.0) MHz MO (Macao) (920.0 to 925.0) MHz RU (Russia) (866.0 to 868.0) MHz SG (Singapore) (920.0 to 925.0) MHz VN (Vietnam) (866.0 to 869.0) MHz TH (Thailand) (920.0 to 925.0) MHz AR (Argentina) (915.0 to 928.0) MHz HK (Hong Kong) (865.0 to 868.0) MHz BD (Bangladesh) (925.0 to 927.0) MHz Brazil (917.4 to 927.2) MHz by using channel selection Chile (917.4 to 927.2) MHz by using channel selection Peru (917.4 to 927.2) MHz by using channel selection Taiwan (922.600 to 927.2) MHz by using channel selection Open Region (859 to 873) MHz and (915 to 930) MHz</p>
Max tag read distance	Up to 9 m (33 feet) with 6 dBi gain antennas

Common software specifications of all AdvanReader-70 models

On-board intelligence	<p>ARM board</p> <ul style="list-style-type: none"> • Cortex A-8 CPU (1 GHz) • 512 MB RAM • 4 GByte ROM with Operating System • 1 x USB connector
On-board software	<p>AdvanNet: advanced driver platform for Keonn components and systems Debian Squeeze (Debian 10.1) based distribution</p>
External software development	<p>AdvanNet based:</p> <ul style="list-style-type: none"> • Test and deploy web-based GUI utility (AdvanNet Monitor) • REST interface that can be used in any development environment
Internal development environments	<p>Java development C development</p>
Operating system	Fully open

AdvanReader-70™

1 or 2 port RFID UHF reader

Common electrical, communication and mechanical specifications of all AdvanReader-70 models



Data communications	Ethernet IEEE 802.3 up to 100 Mbps Ethernet over USB (micro USB Type-B connector) USB HID hardware emulation (USB Type-B connector)
Power supply	Power Over Ethernet (PoE) <ul style="list-style-type: none"> • Supports IEEE 802.3af (Type I) and IEEE 802.3at (Type II) • Power consumption: Class 3I Power supply 24 V (DC) <ul style="list-style-type: none"> • 18 V to 26 V DC Maximum current rating 2.5 A
Output power	5 V (DC) @ 100 mA non-isolated power supply to feed external devices and circuitry
On-board sensors and actuators	Buzzer RTC chip to keep Date&Time between reboots. Battery life time more than 10 years in power off mode.
On-board LED indicators	LED ON (White LED) LED status (Orange LED) LED USB HID Status (Green LED); HID port status
Inputs	2 x digital/analog input 0 V to 3 V (IN 1) 0 V to 10 V (IN 2)
Outputs	4 x digital outputs (100 mA) 1 x digital outputs (8 mA) 1 x relay output (24 VDC / 0.5 A / Resistive load) Loudspeaker (8 ohm / 2 W)
Temperature	Operating temperature: -20 °C to +50 °C Storage temperature: -30 °C to +60 °C
Humidity	20 % to 85 % without condensation
Size	137 mm x 137 mm x 24 mm (5.4 in x 5.4 in x 0.94 in)
Size with enclosure	143 mm x 143 mm x 30 mm (5.6 in x 5.6 in x 1.19 in)
Weight	180 g (6.35 oz)
Weight with enclosure	510 g (18.4 oz)

AdvanReader-70™

1 or 2 port RFID UHF reader

Specifications of AdvanReader-70 with one port

RF connections	One 50 ohm SMA connectors for monostatic antennas
RF Power	Programmable from 0 dBm to 27 dBm in 0.5 dBm steps (Maximum power may have to be reduced to meet regulatory limits)
Max tag read throughput	Up to 50 tags/second
Power consumption	Idle consumption < 3 W Max consumption (@27 dBm) < 7 W

Specifications of AdvanReader-70 with two ports

RF connections	Two 50 ohm SMA connectors for monostatic antennas
RF Power	Programmable from 0 dBm to 30 dBm in 0.5 dBm steps (Maximum power may have to be reduced to meet regulatory limits)
Max tag read throughput	Up to 50 tags/second
Power consumption	Idle consumption < 3 W Max consumption (@30dBm) < 9 W



Mechanical specifications of
AdvanReader-70 with one port

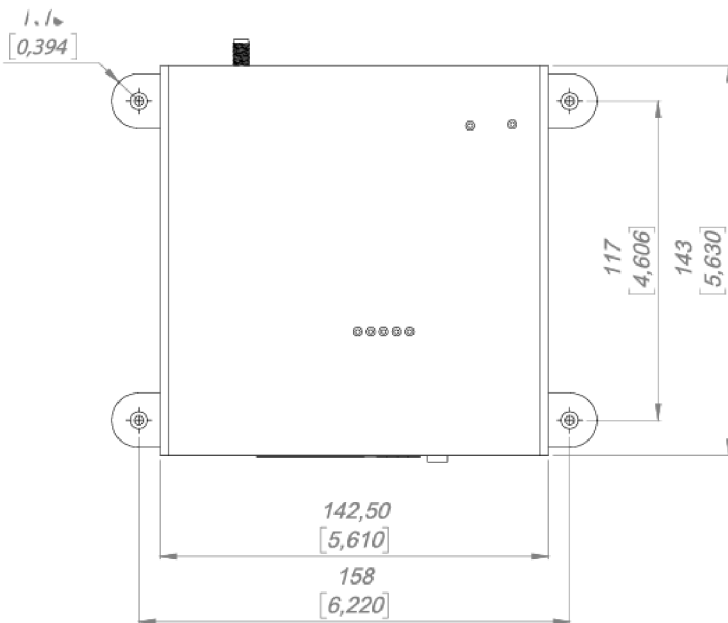
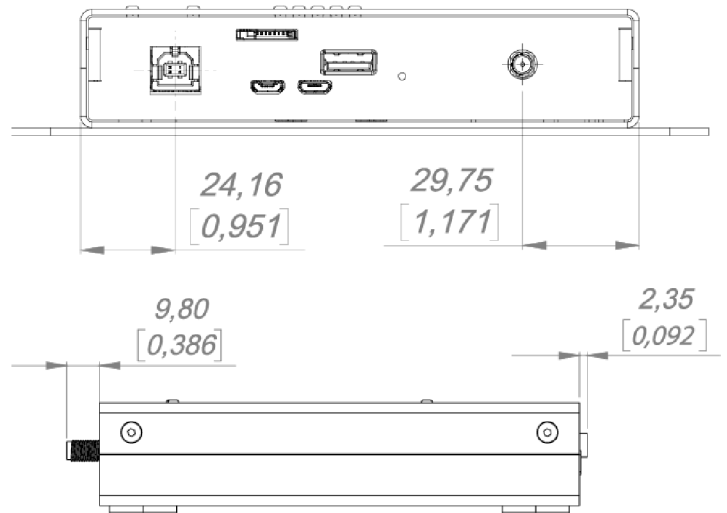
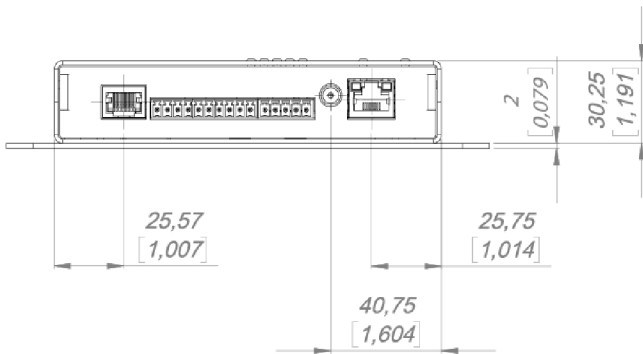
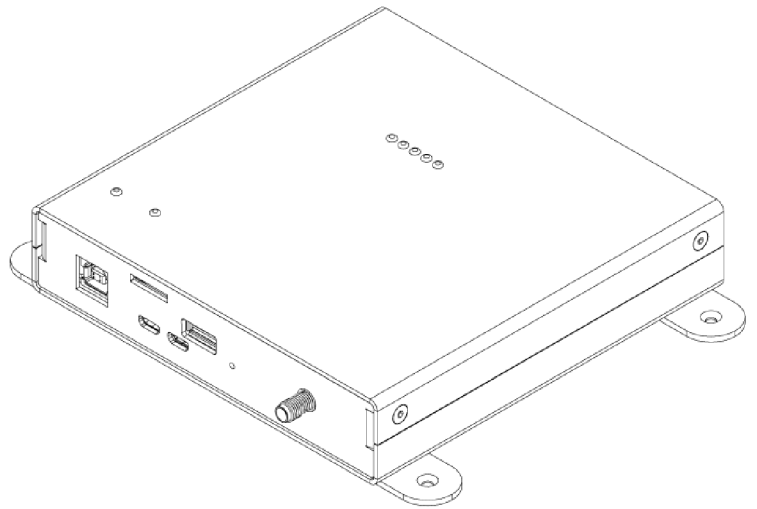

Units in millimeters and [inches]

Mechanical specifications of
AdvanReader-70 with two ports

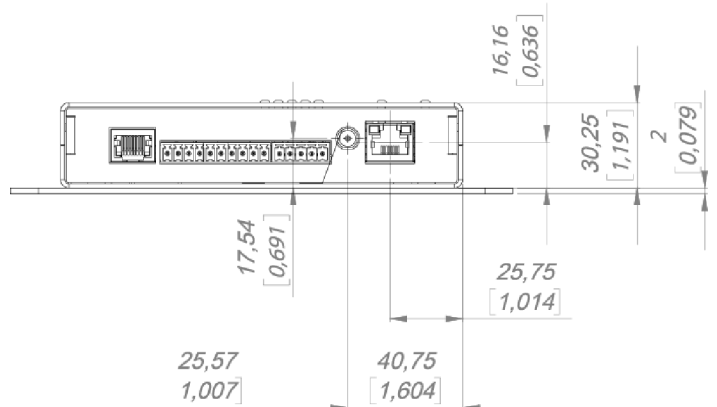
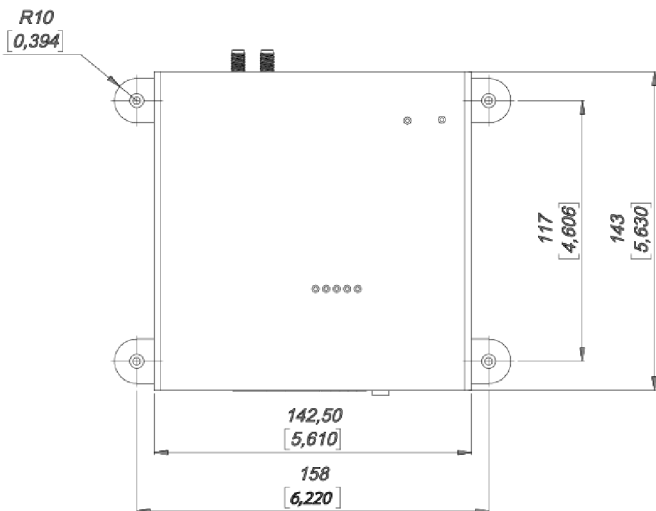
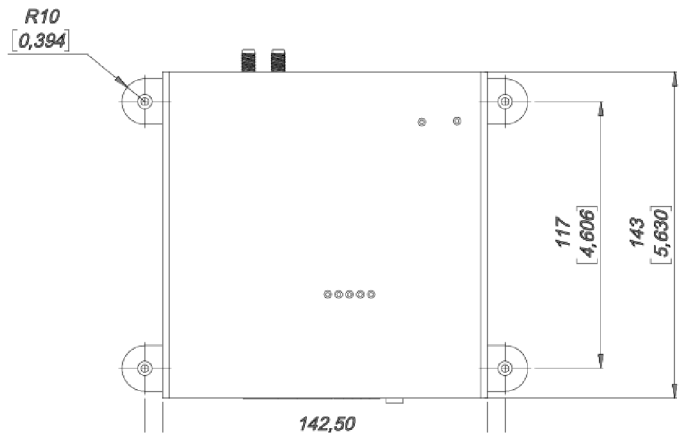
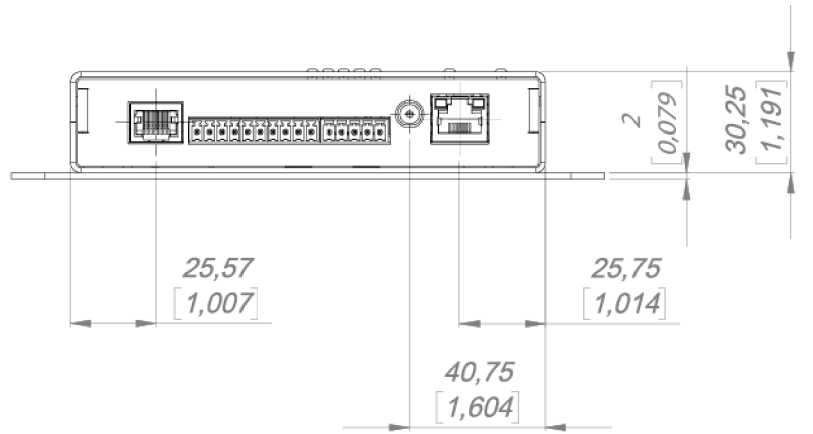

Product codes for ordering

ADRD	-	MX	-	E	CT	-	SC	
								MX = number of ports
		M1						1 port
		M2						2 ports
								E = enclosure
				-				without enclosure
				E				with enclosure
								CT = connector type
					SMA			SMA Straight PCB mount
								SC = series code
							70	Serie 70

Examples:

ADRD-M1-SMA-70:

- AdvanReader
- With 1 port
- Without enclosure
- SMA connector type
- Model **70**

ADRD-M2-ESMA-70:

- AdvanReader
- With 2 ports
- With enclosure
- SMA connector type
- Model **70**



Copyright © Keonn Technologies S.L.
All rights reserved.

Information in this publication
supersedes all earlier versions.
Specifications subject to change
without notice.

