



# ALN-9741

## “Doc” DOCUMENT INLAY

The Alien Technology® ALN-9741 “Doc” RFID inlay is designed for use on paper products such as documents and file folders where tags may be used in close proximity to each other.



### Applications

- Paper/cardboard tagging cal, dental, legal etc)
- Documents • Envelopes
- File folders (e.g. medi- • Booklets

FEATURE	DESCRIPTION	BENEFIT
Dielectrically matched to papers, cardboards and similar printed stock.	Allows tagging of documents, files, booklets and paper products.	Allows tags to be placed on documents or files where these documents will be tightly packed together with many tags in close proximity to each other. These tags have minimal chance of shadowing (hiding each other) from the reader.
Extremely tolerant to close placement of multiple tags.	Specifically designed to reduce shadowing of one tag over another.	
Next generation Higgs™ 4 features and performance	A mass-market optimized tag with class leading read and write performance. Supports Aliens <i>QuickWrite</i> ™ and <i>BlastWrite</i> ™	Rapid programming of serialized tags and excellent read/write performance

### Features:

- › Designed to meet EPCglobal Gen2 (V1.2.0) and ISO/IEC 18000-6C
- › Worldwide operation in the RFID UHF bands (840-960 MHz)
- › 448-Bits of NVRAM Memory
  - 128-EPC Bits
  - 128 User Bits
  - 64 Bit Unique TID
  - 32 Bit Access and 32 bit Kill Passwords
- › Pre-Programmed with a unique, unalterable 64-bit serial number
- › User Memory can be Block Perma-Locked as well as read password protected in 32 Bit Blocks
- › Class leading read and write performance
- › *BlastWrite*™ and *QuickWrite*™ mass-encoding
- › Dynamic Authentication™ - anti-cloning/anti-counterfeit technology
- › Exceptional operating range, up to 11m with appropriate antenna.
- › Available in high-yield, high capacity dry/wet inlay rolls

### Product Overview:

Powered by Alien®’s break-through **Higgs™ 4 UHF RFID IC** and **innovative “Doc” antenna design**, the ALN-9741 delivers industry leading EPC Gen 2 performance and reliability for tagging of papers, files, documents, folders or other thin and tightly compact wood/organic materials.

With its Higgs-4 core, the Doc tag delivers next generation read and write performance, yet is completely **optimized for the highest volume applications.**

An optimized memory footprint includes a 32-bit TID, a **64-bit Unique TID for authentication** and **next generation serialization** applications, a 128-bit EPC memory bank, 128-bits of user memory for distributed data applications, and **password protected read and write** support capabilities to prevent unauthorized viewing and modification of the tag’s data.

ALN-9741 inlays are World Tag compliant, enabling consistent operation across the diverse frequencies of the Americas, Europe, Middle East, Asia, and Africa.



All dimensions in millimeters unless specified otherwise

### ALN-9741 Antenna Size

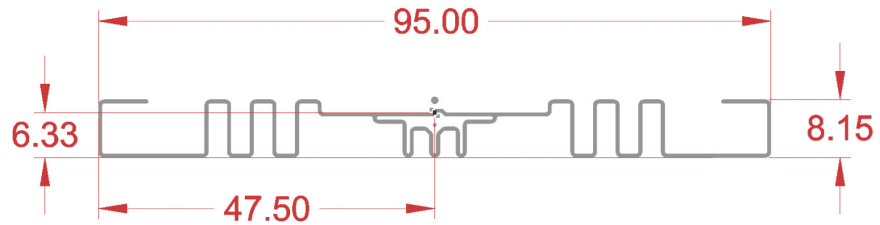

ALN-9741-R (Dry Unslit Roll)

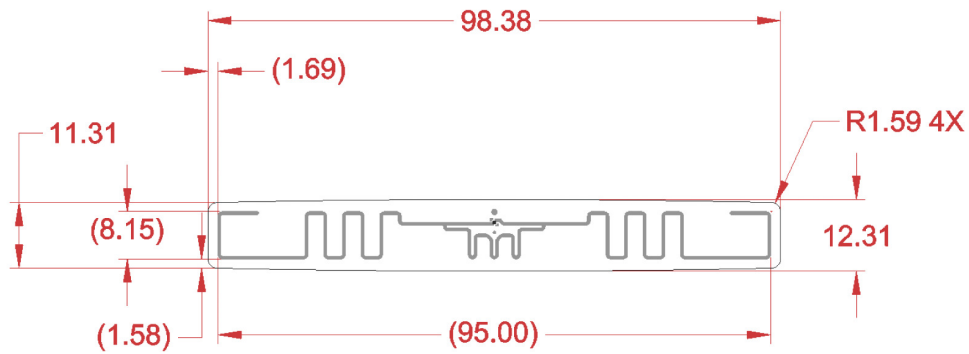

ALN-9741-WRW (White Wet Inlay)

### ALN-9741 Inlay Orientation

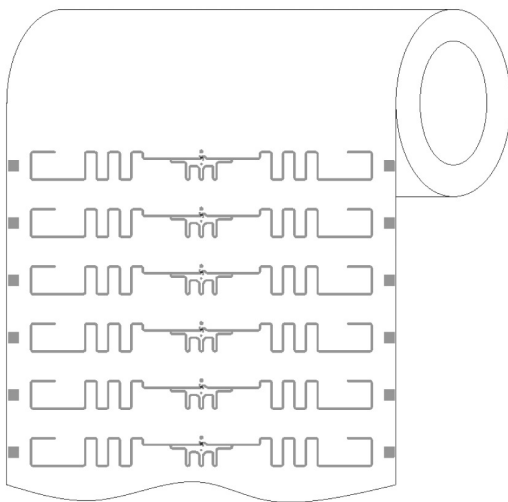

ALN-9741-R (Dry Unslit Roll)

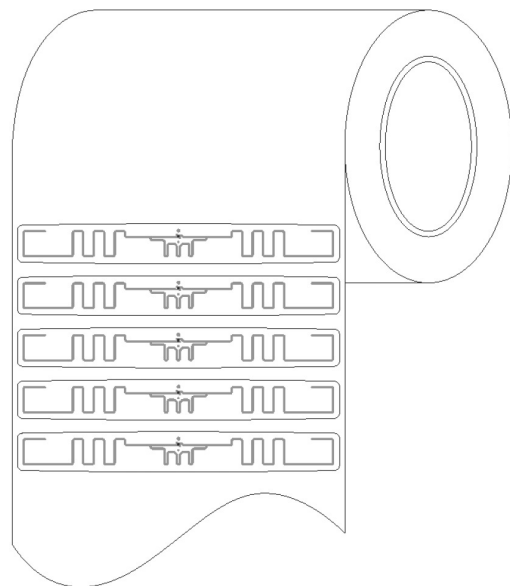

ALN-9741-WRW (White Wet Inlay)

Standard Alien Inlay rolls unwind with metal antenna side facing outward, with respect to the core.

### ALN-9741 Inlay Specification

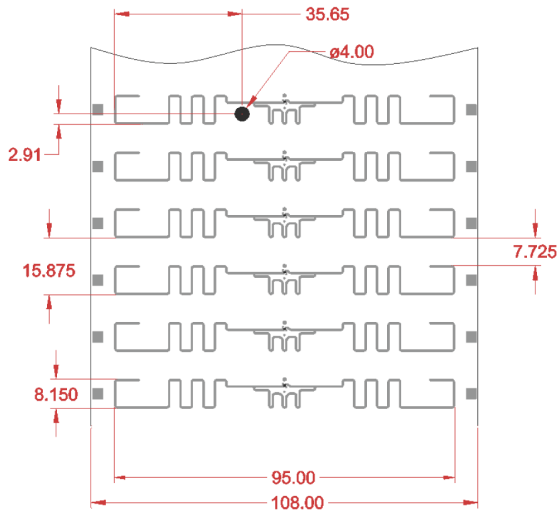

ALN-9741-R (Dry Unslit Roll)

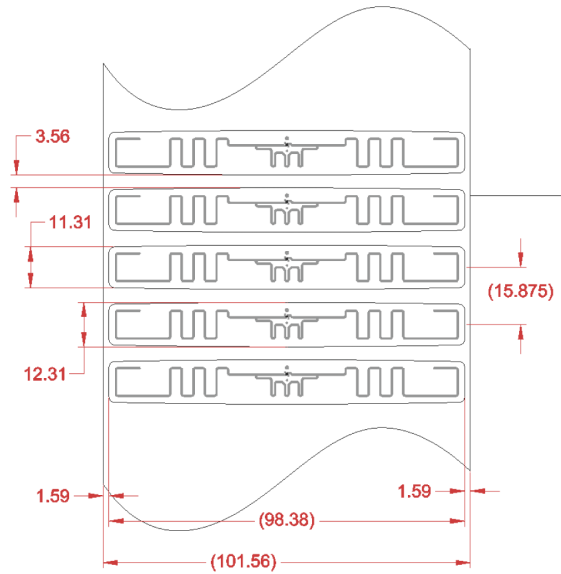

ALN-9741-WRW (White Wet Inlay)

### ALN-9741 Inlay Stackup

DRY INLAY THICKNESS, ±10%	
OVER ANTENNA	0.05 mm
OVER CHIP	0.25 mm

WHITE WET INLAY THICKNESS, ±10%	
OVER ANTENNA	0.16 mm
OVER CHIP	0.36 mm

INLAY

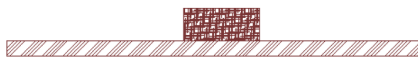

ALN-9741-R  
(Dry Unslit Inlay)

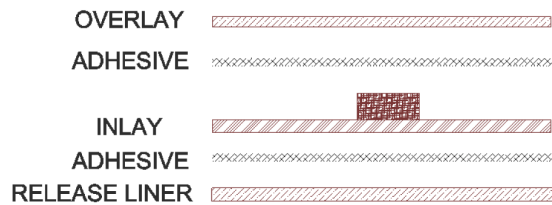

ALN-9741-WRW  
(White Wet Inlay)



### ALN-9741 Inlay Angular Sensitivity

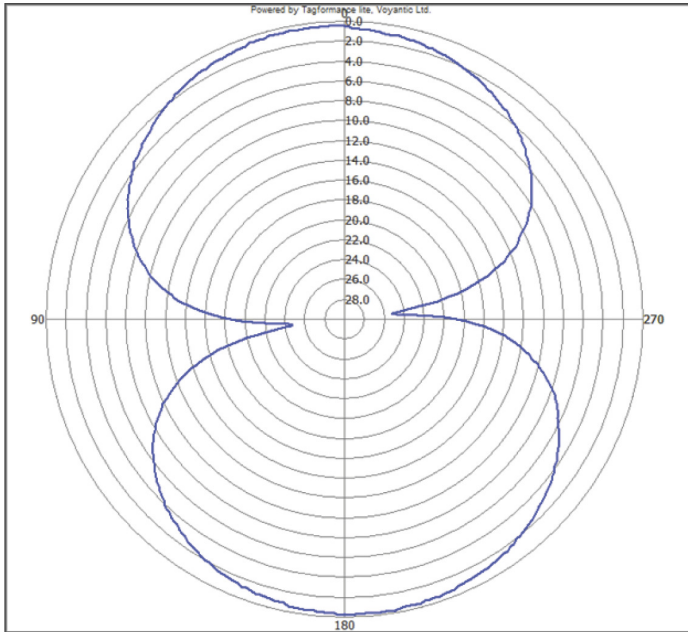

Angular Sensitivity  
(Relative Read Range vs. Orientation)

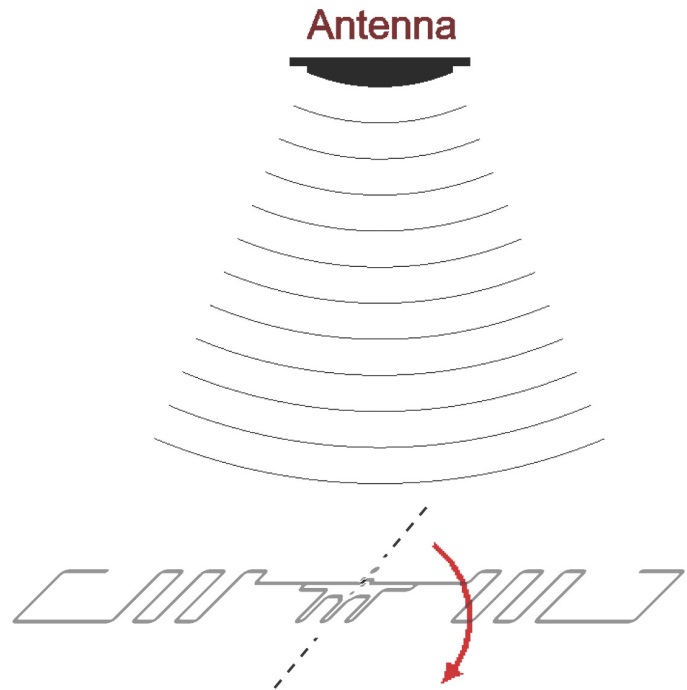

Angular Sensitivity  
Inlay is rotated in the x, y, plane about the z axis

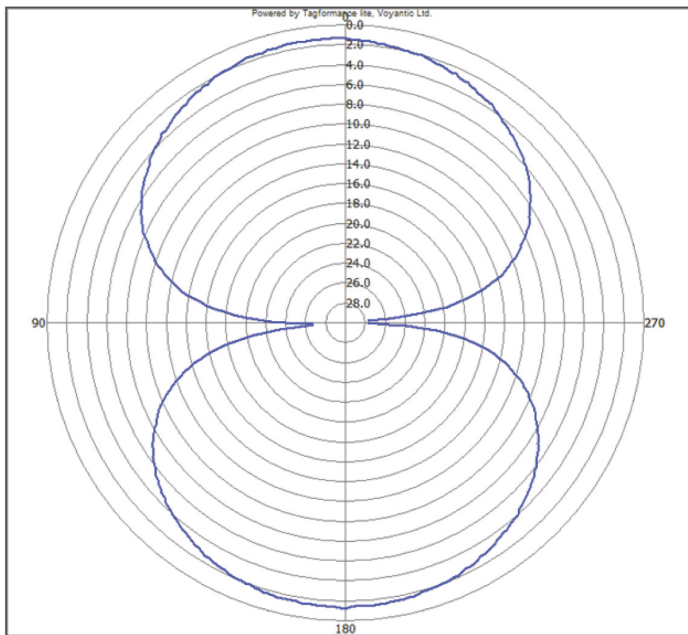

Angular Sensitivity  
(Relative Read Range vs. Orientation)

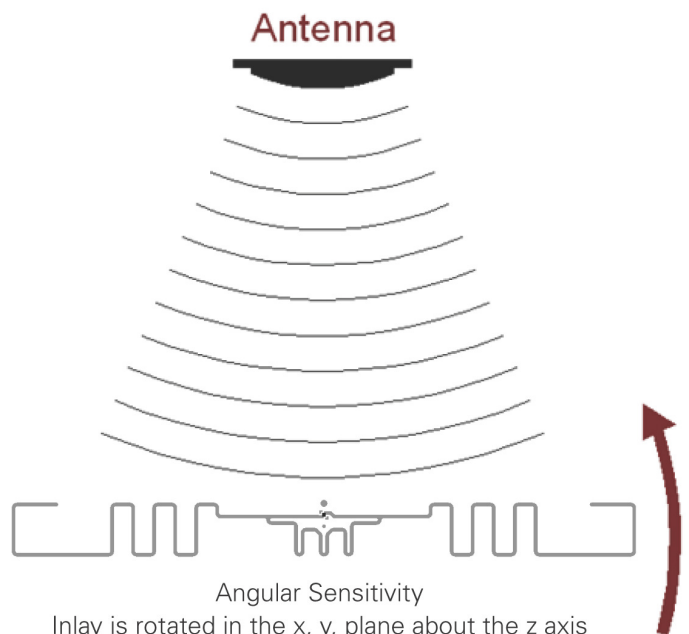

Angular Sensitivity  
Inlay is rotated in the x, y, plane about the z axis  
(tag shown at 0° with respect to face of antenna)



## ALN-9741 Specifications

### Dry Inlay

Antenna Width	3.74" [95mm]
Antenna Length	0.32" [8.15mm]
Web Width	4.25" [108.0mm]
Web Pitch	0.625" [15.875mm]
Core Width	4.25" [108.0mm]
Core ID	6" [152.4mm]*
Core Material	Fiberboard
Inlays per Roll	20,000 Nominal
Maximum Roll OD	< 12" [304.8mm]
Roll Labeling Data	Roll #, Quantity

### Wet Inlay

Inlay Width	3.87" [98.38mm]
Inlay Length	0.49" [12.31mm]
Web Width	4.00" [101.56mm]
Web Pitch	0.625" [15.875mm]
Core Width	4.00" [101.56mm]
Core ID	6" [152.4mm]*
Core Material	Fiberboard
Inlays per Roll	20,000 Nominal
Maximum Roll OD	< 16" [406.4mm]
Roll Labeling Data	Roll #, Quantity
White	TT Printable White Film Only
Overlay Adhesive	General Purpose Permanent
Inlay Adhesive	General Purpose Permanent
Adhesive Application Temperature	> +25°F [-4°C]
Adhesive Service Temperature	-40°F to +200°F [-40°C to +93.3°C]
Release Liner	40# SCK

### Environmental

Shelf Life	Dry Inlays: 5 years at +77°F [+25°C] @ 40% RH Wet Inlays: 2 years at +77°F [+25°C] @ 40% RH
Recommended Storage	+77°F [+25°C] @ 40% RH
Storage Limits	-13°F to 122°F [-25°C to +50°C] 20% to 90% RH Non-condensing
Operating Limits	-40°F to +158°F [-40°C to +70°C] 20% to 90% RH Non-condensing
Bend Diameter	> 1.97" [50mm]
Pressure	< 5N/mm <sup>2</sup>
Drop Resistance	Per ASTM D5276
Write Cycles	100,000 @ 25°C
RoHs	2002/95/EC, 2005/618/EC, 2011/65/EU Compliant
REACH	1907/2006/EC Compliant (SVHC and ECHA)
ESD Limit— HBM / CDM	5.0kV / 1.5kV

### RFID

Protocols Supported	ISO/IEC 18000-6C EPCglobal Class 1 Gen 2
Integrated Circuit	Alien Higgs-4
Operating Frequency	840–960 MHz
EPC Size	128 Bits
User Memory	128 Bits
TID	32 Bits
Unique TID	64 Bits
Access Password	32 Bits
Kill Password	32 Bits

\* Shipped with 6" to 3" plastic core adapter  
July 5, 2016

Copyright © 2016 Alien Technology LLC. All rights reserved.

Alien, Alien Technology, the Alien Technology logo, Spider, Higgs, Dynamic Authentication, QuickWrite, BlockWrite, Squiggle, and the Squiggle logo are trademarks or registered trademarks of Alien Technology Corporation in the U.S. and other countries.

HANDLING PRECAUTIONS Observe standard handling practices to minimize ESD.

DISCLAIMER Application recommendations are guidelines only - actual results may vary and should be confirmed. This is a general purpose product not designed or intended for any specific application.

This product is covered by one or more of the following U.S. patents: 7967204, 7931063, 7868766, 7737825, 7716208, 7716160, 7688206, 7659822, 7619531, 7615479, 7598867, 7580378, 7576656, 7562083, 7561221, 7559486, 7559131, 7554451, 7551141, 7542301, 7542008, 7531218, 7522055, 7506610, 7489288, 7453705, 7425467, 7417306, 7411503, 7383284, 7377445, 7364084, 7353598, 7342490, 7324061, 7321159, 7301458, 7295114, 7288432, 7265675, 7262686, 7260882, 7253735, 7244326, 7218527, 7214569, 7199527, 7193504, 7173528, 7172910, 7172789, 7141176, 7113250, 7101502, 7080444, 7070851, 7068224, 7046328, 6998644, 6988667, 6985361, 6980184, 6970219, 6952157, 6942155, 6933848, 6927085, 6816380, 6780696, 6731353, 6693384, 6683663, 6665044, 6657289, 6623579, 6606247, 6606079, 6590346, 6586338, 6566744, 6555408, 6527964, 6479395, 6468638, 6420266, 6316278, 6291896, 6281038. Other patents pending.

This product is licensed under patents of Round Rock Research, LLC, for use solely with UHF RFID Readers (such as Alien reader products) that are licensed under an agreement with Round Rock Research, LLC.



1.888.238.1155 • Inside USA  
1.205.383.2244 • Outside USA

info@atlasRFIDstore.com • www.atlasRFIDstore.com